

Week 4: 3D Modeling - Assemblies

Concepts

- Lesson on degrees of freedom
 - An introduction to assembly Mates
 - Mate Connectors
 - Manipulating part position with the triad
 - Explaining Mates and Relations
 - Animating Mates
 - An introduction to Linked Documents
 - Applying limits to a Mate
-

Models

- BU35 Cantilever Clamp
- Assembled Vise

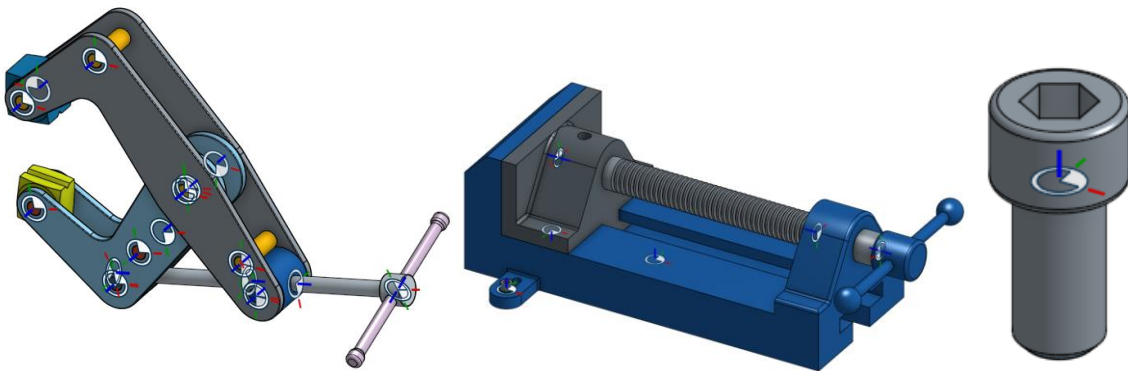

About Assemblies

Until now, we've been designing single parts and Multi-Part designs in Onshape Part Studio tabs, but now we will discuss **assemblies**. In Onshape, Assembly Tabs allow us to assemble multiple part instances (or assemblies) together, and define the motion (if any) between them. In the dynamic world we live in, mostly everything has some sort of movement, so learning how to create, build, and simulate motion with assemblies is an important topic. For example, the common retractable pen is an assembly; the spring-loaded ink cartridge slides up and down the main casing. Most everything we deal with in engineering (design, test, manufacture, buy, sell) is an assembly of some sort.

For designing and manufacturing an assembly, it is important to know which parts go into the assembly, how many of each, how they are assembled, and how they should perform. All of this critical information can be documented by creating an assembly in Onshape, and then creating a drawing of that assembly (which will be covered in the next class).

In an Assembly Tab, we have a new set of tools to use, and therefore we have a new toolbar. Where a Part Studio utilizes Sketches and Features, Assembly Tabs utilize **Mates** and **Relations**:



This toolbar allows us to insert parts and subassemblies, and create and manage the kinematic constraints between parts. More information on Assemblies can be found in the Onshape Help here: <https://cad.onshape.com/help/index.htm#assembly.htm>

Before we get started...

A Note about Mate Connectors in Onshape

Much like in sketching, where constraints are used to create relationships between sketch entities, **Mates** are similarly used to locate parts within an assembly and define the relative motion between parts. For example, parts may slide, rotate, swing, etc. Also, just like in sketching, it is best practice to “fully constrain” parts in an assembly by using just enough mates to fully define the assembly’s motion. In order to accomplish this, you must create relationships (called mates), which limit a part’s **degrees of freedom**. All unconstrained objects have 6 degrees of freedom in 3D space: these include translation in the X, Y, and Z directions, and rotation about the X, Y, and Z axes. If a part is able to move in n number of directions and rotations, we say that the part has n degrees of freedom.

Typically, CAD software defines each part's location and orientation in an assembly by using a set of "Assembly Constraints". An Assembly Constraint typically includes a pair of geometric references: one reference to the part in question, and another reference to another, already assembled part. For example, when assembling a bolt into an already existing plate, a typical set of constraints would be:

1. Constraint #1: Constraining the bottom of the bolt head to be coplanar with the top surface of the plate.
2. Constraint #2: Constraining the diameter of the bolt to be concentric (coaxial) with the diameter of the hole in the plate.
3. Constraint #3: Constraining/preventing the rotation of the bolt within the hole (this is optional).

It is quite common to either omit or "automatically solve for" the third constraint. Remember, in real life, the rotation of the bolt is actually determined by the thread, and that detail is not needed in the CAD model. The graphic below shows the typical steps in CAD. On the left side, the bolt is shown unconstrained, or "floating" in the air above the plate, and on the right side, the bolt is shown fully constrained in place.

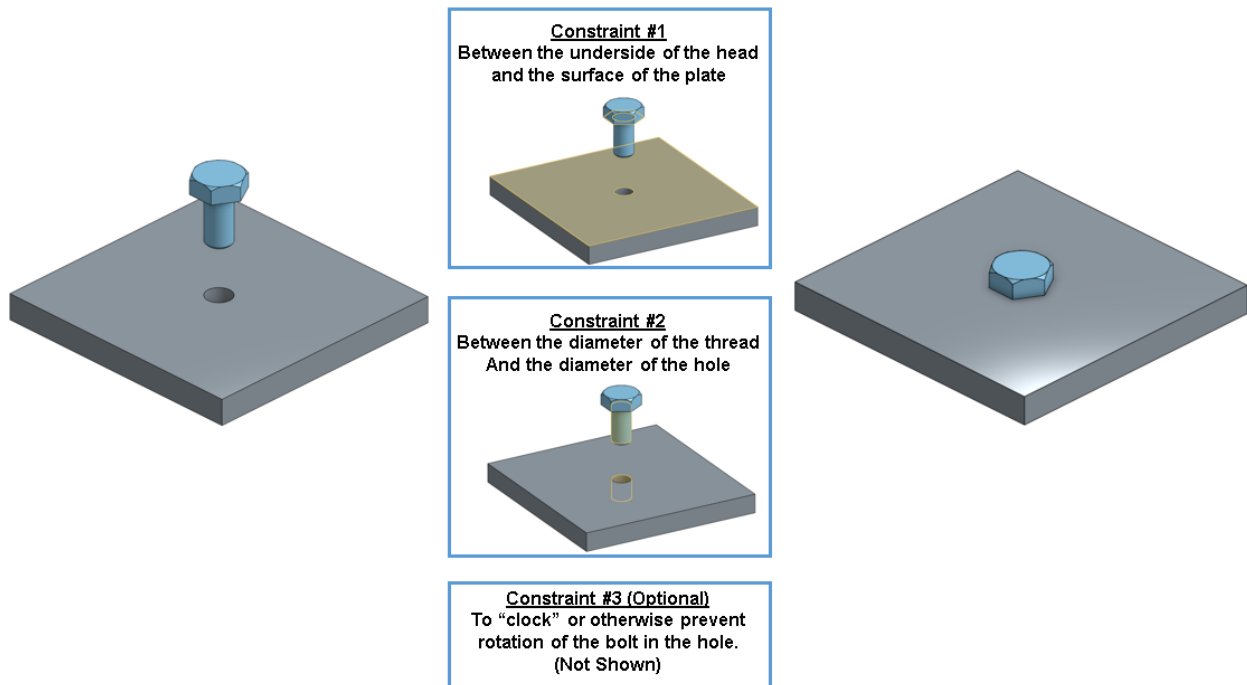

Despite this being the "norm", it is not the most efficient. The reason being is that there are three constraints that need to be created and managed. If the part is going to be moved, then 3 constraints need to be updated, and if the part needs to be replaced, then 3 constraints need to be replaced. In addition, if the joint, or geometry between the part and the assembly is changed in any way, then three constraints need to be addressed. Finally, if there is any relative motion

between the parts, that may need to be manually added into the CAD model in addition to the assembly constraints!

Onshape has developed a new way to create and manage assembly constraints, and that is with a single “High-Level Mate” that is used to constrain a part to another part. A Mate in Onshape fully describes how two parts will interact with each other by specifically controlling each degree of freedom through the use of things called **Mate Connectors**. You can think of a Mate Connector as a small, local coordinate system (an x, y, and z axis) for a joint between two parts. The Red line is the X-axis, the Green is the Y, and the Blue is the Z. The Blue axis usually points in the axis of circular and cylindrical components. This is what a Mate Connector looks like in Onshape:

2-D View



Isometric View



In Onshape, you first select the type of Mate you want to apply to the two parts, and a Mate Connector appears for each part. The Mate Connector specifies the orientation and location of the parts, while the Mate specifies the degrees of freedom, or the relative motion between the parts. All the information needed to constrain a part in an assembly is contained in a single Mate.

In short, each Mate in Onshape is comprised of a pair of Mate Connectors, one for each part. Below is the previous assembly workflow using a single Mate and Mate Connector Pair.

In this Mate, the base of the bolt head and the top of the plate are selected to perform the Fastened mate (which automatically constrains all 6 degrees of freedom so that the two parts cannot move relative to one-another), and the Mate Connectors are oriented such that the Z axes (blue) both point upwards:

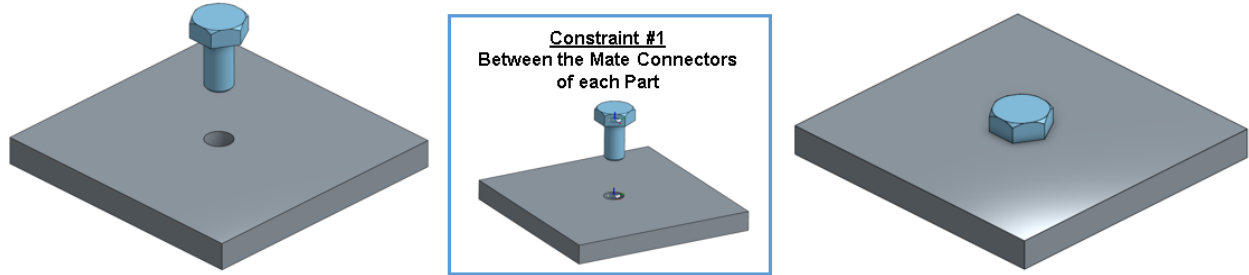

Once the mate has been created, it can be used, changed, replaced or updated quickly and easily. For most applications, a single Mate is used to fully constrain a part, thus doing the work of 3 or more “typical” assembly constraints. Not only is using the Mate Connector quicker, easier, and more versatile than the traditional “3 constraint” method, it is much easier to simulate motion, as we will see with the following examples.

To prepare for this lesson it is best to go through the material on the Onshape Help. First review the section about Mate Connectors: https://cad.onshape.com/help/#mateconnector_a.htm and the section about the different kinds of Mates: <https://cad.onshape.com/help/#mate.htm>. It would also be helpful to review the help section about the triad: <https://cad.onshape.com/help/#triad.htm>.

Assemblies

Let’s use our Top-Down Cantilever Clamp Design from the last lesson to build a fully functioning assembly with movement. Here is a picture of it fully assembled, with all of the Mate Connectors shown:

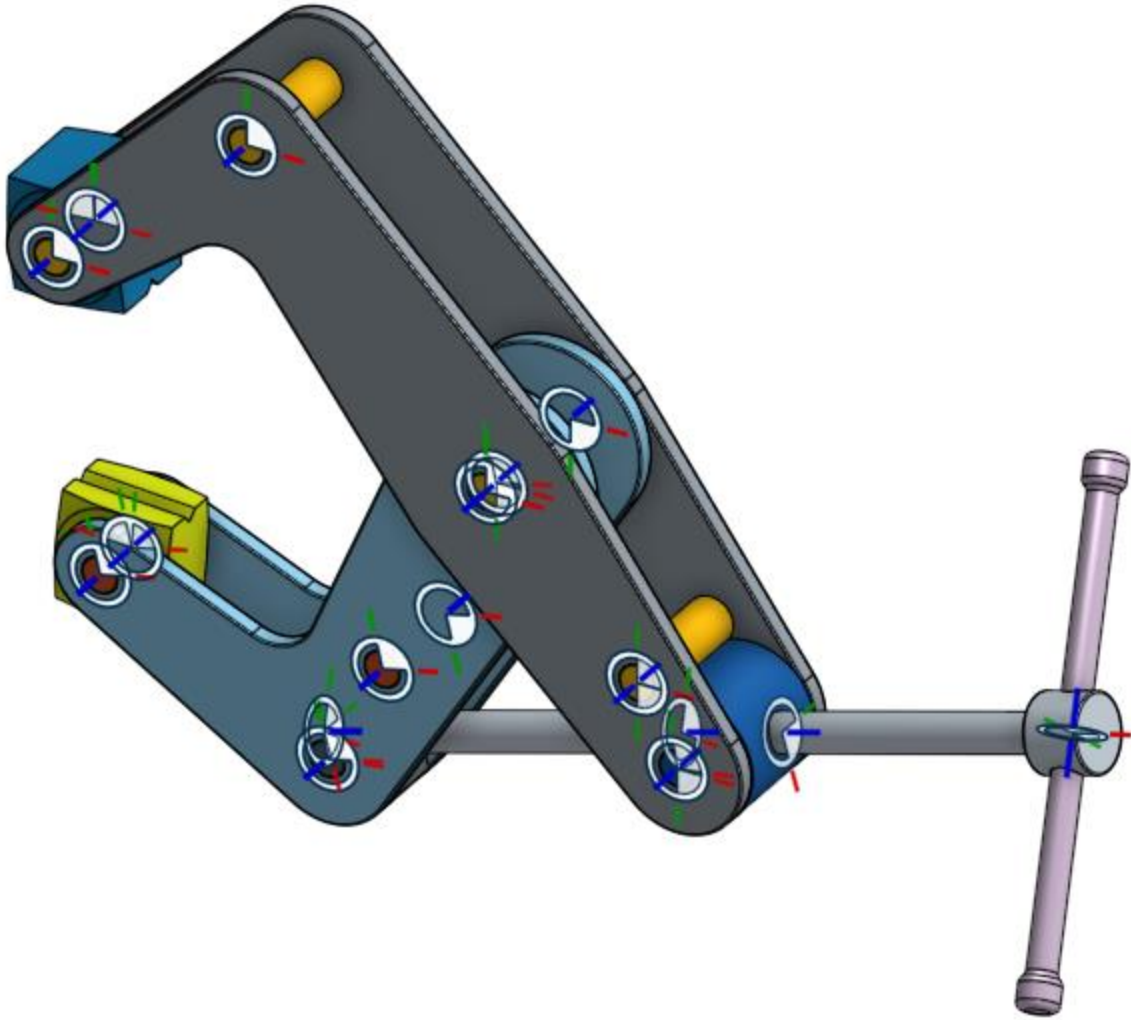

The goal of this moveable assembly is to twist the handle to rotate and move the shaft, bringing the grips closer together so that it can clamp something.

1. First, let's insert the Large Arm by clicking on the  Insert button, and selecting the Large Arm, then immediately selecting the Green Check Mark. When the Green Check mark is immediately selected, the part is placed at the origin. This is the best practice for the first part of an assembly.

Instances (1)
Origin
Large Arm <1>
▼ Mate Features (0)

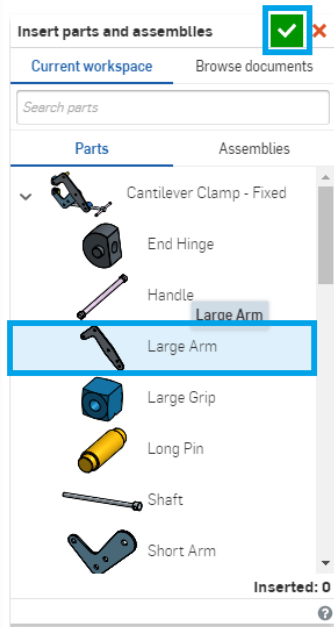

2. With the Large Arm at the origin, right-click it in the Parts List, and select "Fix" (Doing this makes sure that the part will never move):



Instances (1)
Origin
Large Arm <1>
▼ Mate Features (0)

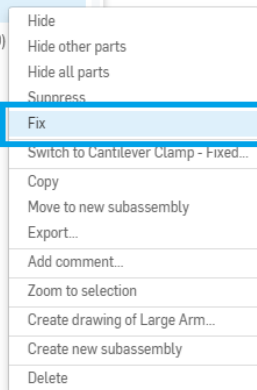

Pro Tip: Fixing the first part in an assembly is the best practice in any CAD tool. The reason being is that the first part acts like a foundation for the rest of the assembly (much like the foundation of a house acts as a solid footing for the walls and the roof). Another way to think about it, is building an assembly in CAD is really just the simulation of building things in real life. On an assembly line, parts are usually held in place so they don't move while additional parts are assembled on to them. Imagine trying to change a tire while your car is rolling down a hill! In Onshape, when a part is fixed, an icon is shown to the right of the part in the Parts List like this:

Large Arm <1> 

3. Next, let's insert the Short Arm, and also place it at the origin:



Triad Manipulator

4. Although it appears to be in the correct location, there are no Mates keeping it there, and so if we were to select the part, we could use the triad to move it. Click and drag the arrows to translate the part. Click and drag the circles to rotate it. Using the Triad, drag the Short Arm to the left:

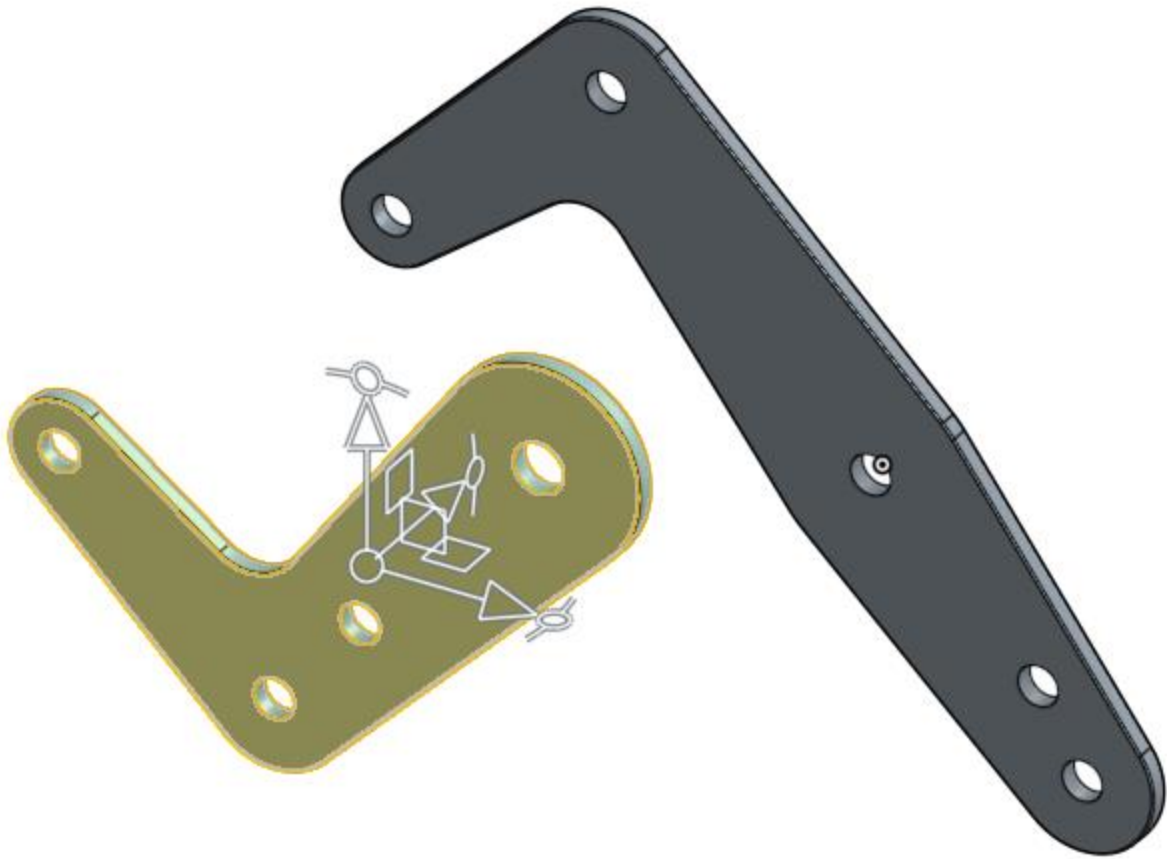

5. The intent here is to create a working Cantilever Clamp with realistic motion, so let's create a Mate between the two arms. Since we want to allow the arms to rotate relative to each other, we'll choose the revolute mate. Note that the revolute mate constrains the parts to move in one degree of freedom (rotation about the Z (blue) axis):

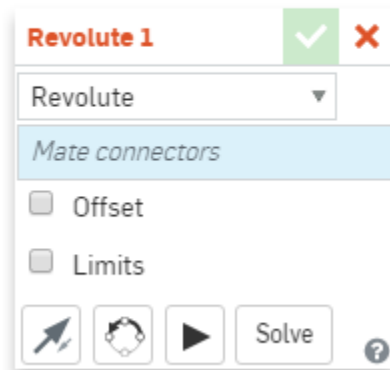

6. Since a Mate is a constraint between a pair of parts, it needs a pair of Mate Connectors (one from each part) to define it. Note that the Mate Connector snaps to many positions on the part, including centroids of faces and midpoints/endpoints of edges. In this case, we have a pair of holes from the arms that we want to line up, and so we will focus there. Hover over the hole in the Short Arm, and Onshape will preview the location of a Mate Connector at the hole (You may need to zoom closer to the hole). As mentioned earlier, the Z axis (blue) should point in the axis of the cylindrical hole. A single left click will accept the Mate Connector:

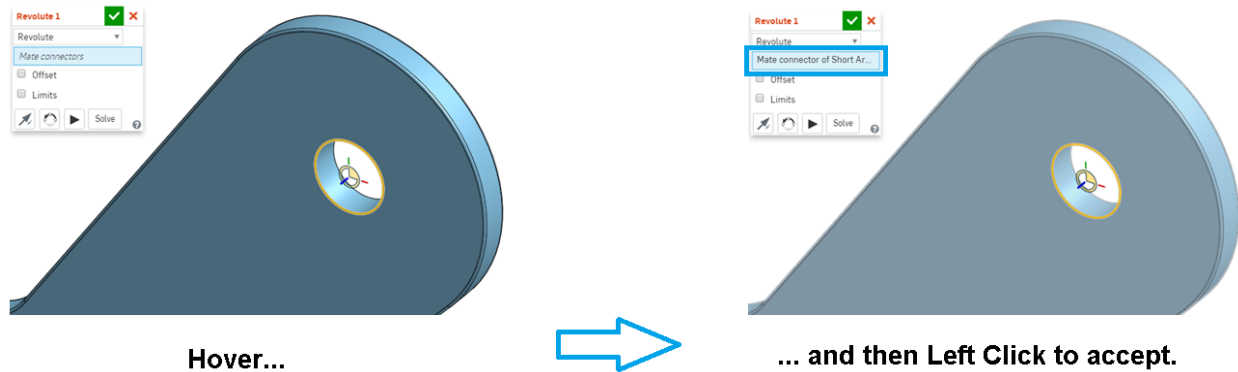

Pro Tip: This will take a little getting used to, so be patient. As you hover the mouse over the parts in question, Onshape will continuously guess where you want to place the Mate Connector. One way to “filter” how Onshape guesses is to hold the [Shift] key down while hovering. This will “lock” Onshape’s focus onto the geometry in question. Try it! Holding the shift key down while hovering over the front face of the Short Arm shows all of the potential locations a Mate Connector could go on that face (small white icons). How many can you count? (The answer is 18!) The Mate Connector shown below is located at the centroid of the area of that face:

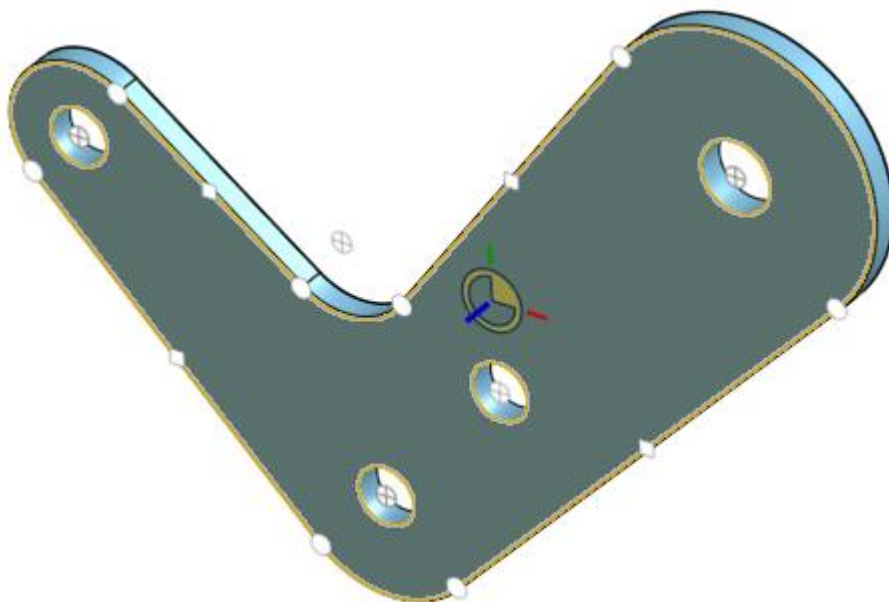

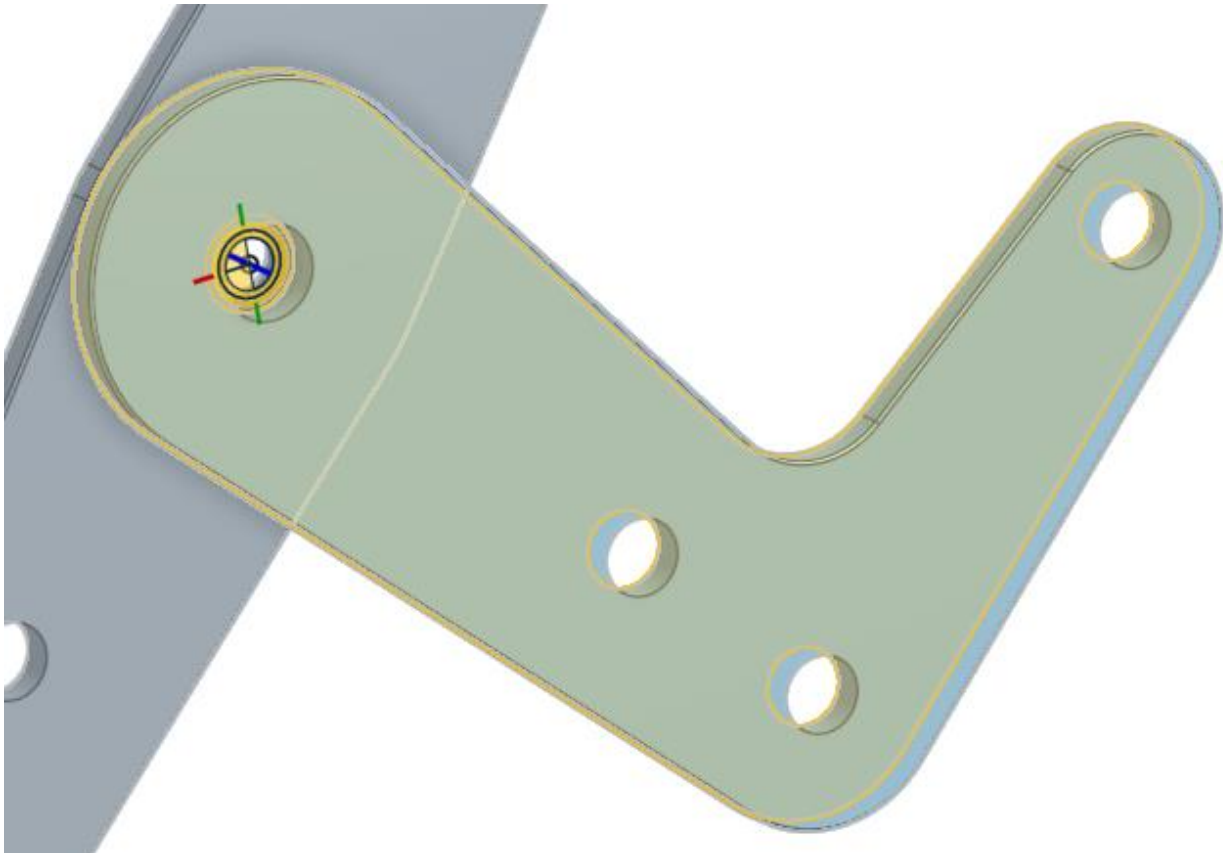

7. Okay, now that we have the first Mate Connector on the Short Arm created, let's create the Mate Connector on the Large Arm. To do this, we need to rotate the model around such that the Blue axis points normal to the face of the part you want to perform the mate on. Select a Mate Connector on the accompanying hole in the Large Arm. Try to use the "Hover, [Shift], Left Click" workflow discussed above in the Pro Tip. Once selected, the parts will snap together:



Pro Tip: Note the orientation of the Mate Connectors in the picture above. The blue axes of the Mate Connectors are lined up. This is very important, because it is the blue axis which determines the axis of rotation for the Revolute Mate (joint). Except for some rare cases, the blue axis should always line up with the axis of a hole. In most cases, Onshape will do this automatically. Also, up to this point, we have only used Mate Connectors that Onshape auto-populates for us. In many cases, this is all you'll need. However, as we'll see later, you can actually manually create Mate Connectors in very specific locations and orientations.

Animations

Animations are a great way to view the motion of your Mate before accepting it. Onshape will automatically move the Mate in a way that will exercise the Degrees of Freedom. In a Revolute Mate the part will rotate, in a Slider Mate, the part will slide, in a Cylinder Mate, the part will slide and rotate, etc.

8. Before we accept the Mate, let's animate the Mate to verify that the rotation is in the direction we want. Click on the animate  icon in the dialog box. The Short Arm should rotate in the desired direction. If it doesn't, delete and redefine the Mate Connectors until it does, then select the Green Check Mark  :

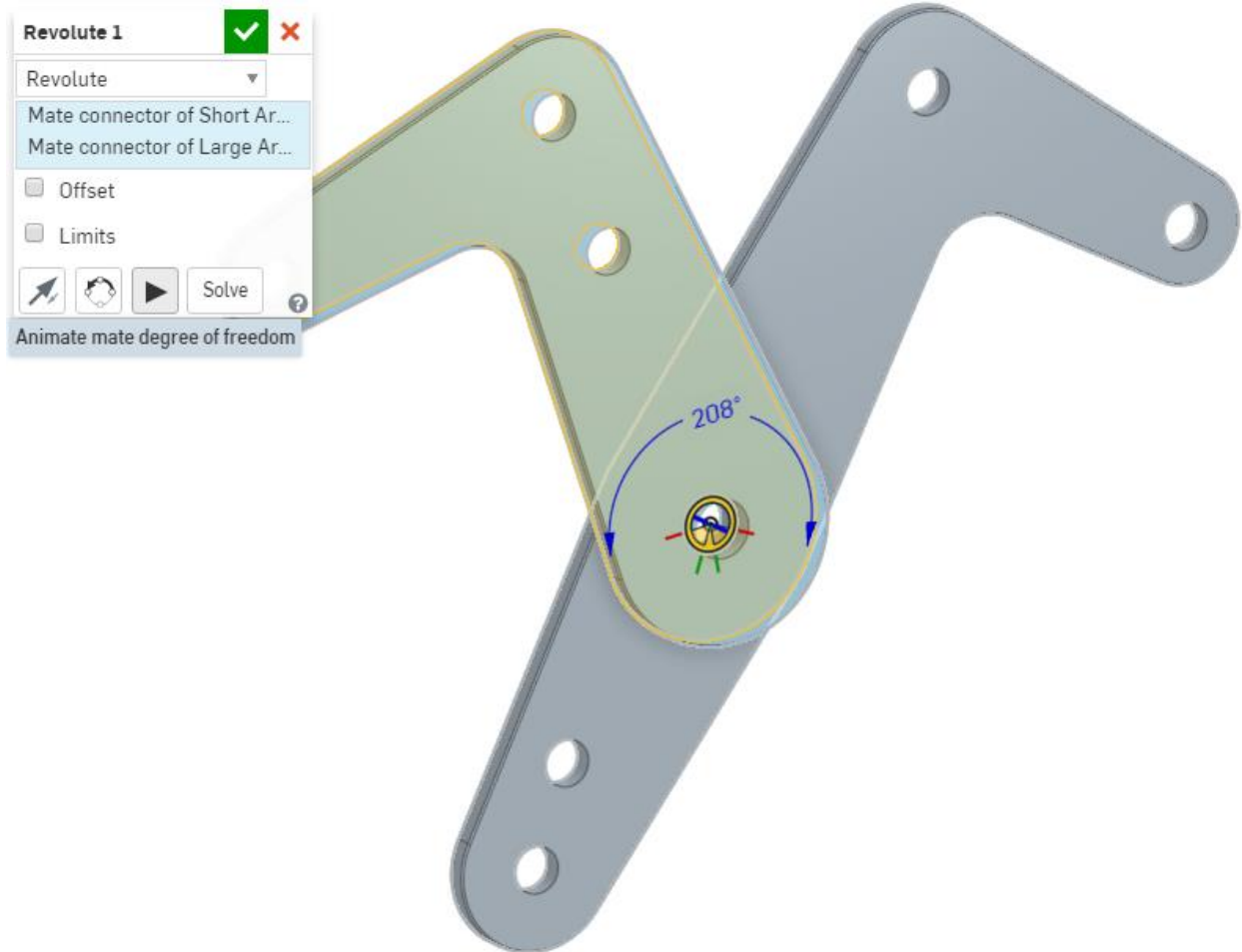

9. Okay, now let's assemble the End Hinge to the Short Arm. Insert the End Hinge, and Create a Revolute Mate. First, we'll create a Mate Connector on the End Hinge. Hover over the cylindrical surface of the End Hinge, hold down the [Shift] key, and then select the point at the base of the pin:

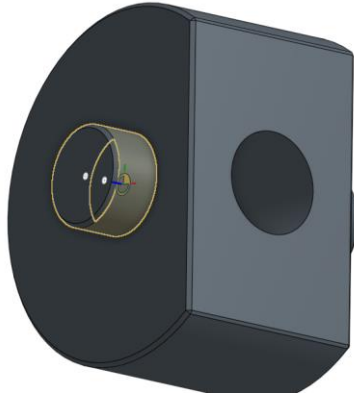

Pro Tip: There are two other methods to put a Mate Connector at this location, (1) by hovering over the circular edge of the pin, shown on the left below, and (2) by hovering over the face of the End Hinge, shown on the right below. All three methods are acceptable:

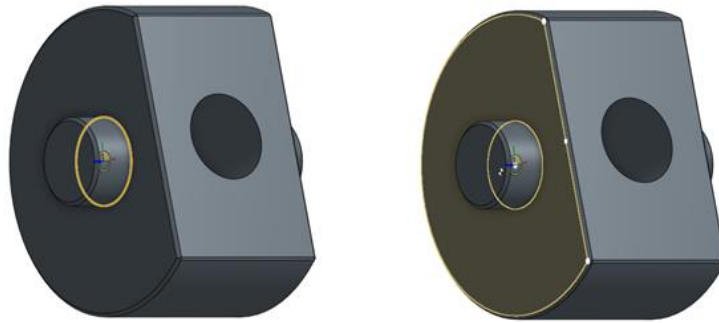

10. Now, create a Mate Connector on the hole of the Short Arm, and accept the Mate. The part should now look like this:

Instances (3)

Origin

Large Arm <1> 

Short Arm <1>

End Hinge <1>

▼ Mate Features (2)

>  Revolute 1

>  Revolute 2



11. Next, let's assembly the threaded hinge using a revolute mate using the same workflow as we did with the end hinge. Test out the movement of the clamp, by clicking on the Short Arm and rotating it:

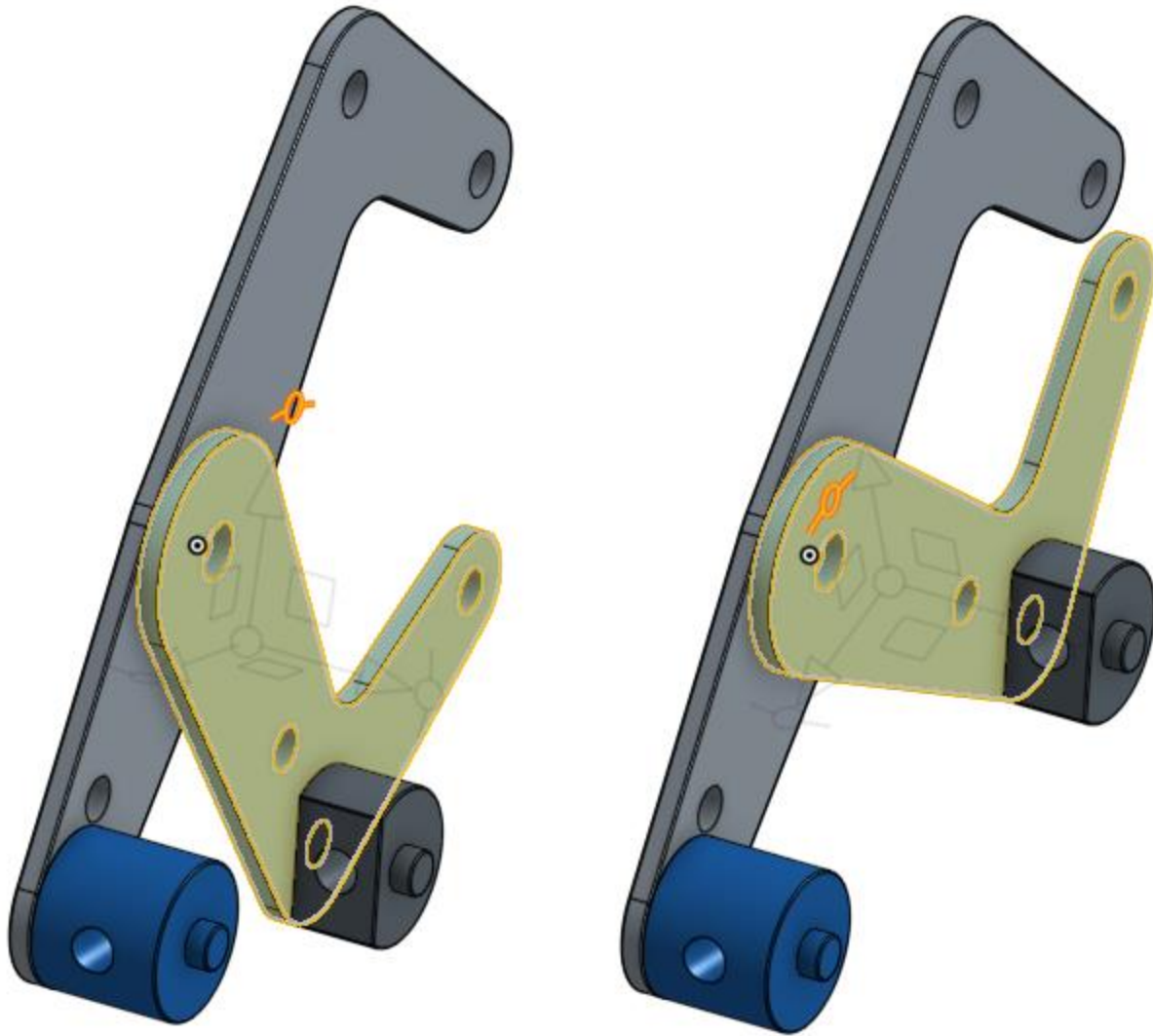

12. Now, let's Assembly the pins to the Arms. Let's start by inserting all of the long pins, and just placing them out in space somewhere. Note that you can insert the same part into the assembly more than once:

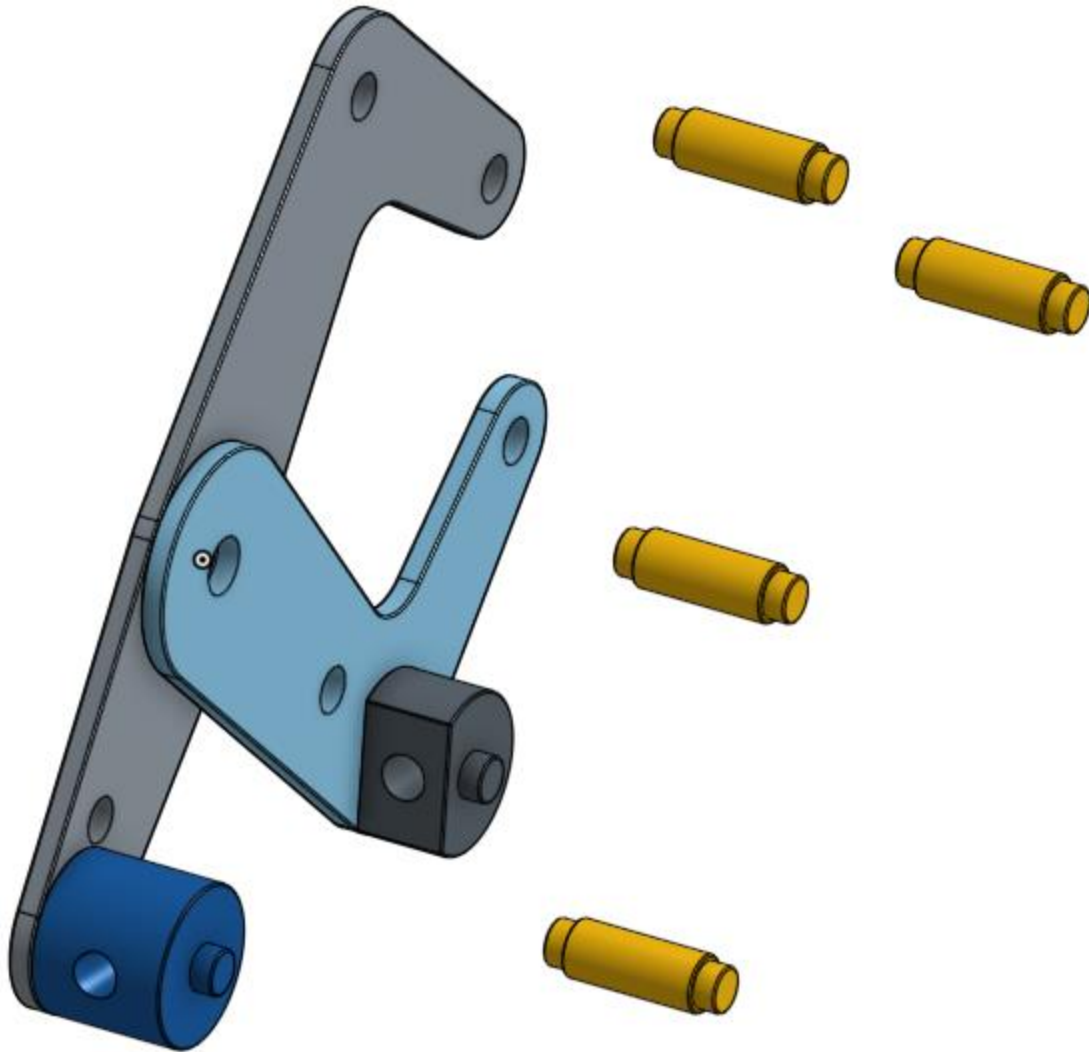

13. Since the Pins do not rotate (in real life, they are pressed in place) we can use a Fastened Mate, .

14. Let's start with the pin in the middle. Temporarily hiding the Short Arm, will make it easier to see the surfaces we need. In this case, we want to use the diameter and shoulder of the pin/hole, because that is the most realistic. Here is the workflow and the final solution:

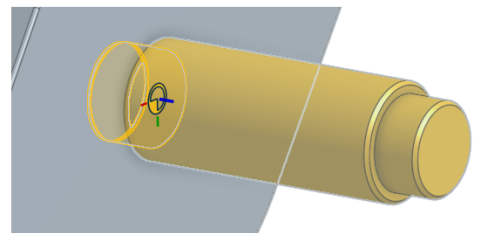
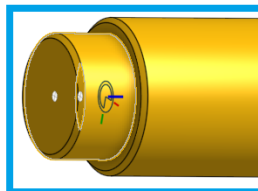
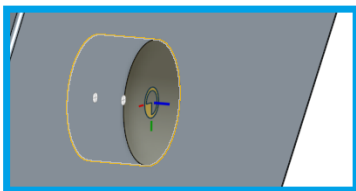

15. Repeating the process for the other Long Pins, the assembly should now look like this:

Instances (8)

Origin

Large Arm <1> 

Short Arm <1>

End Hinge <1>

Threaded Hinge <1>

Long Pin <1>

Long Pin <3>

Long Pin <4>

Long Pin <5>

▼ Mate Features (7)

>  Revolute 1

>  Revolute 2

>  Revolute 3

>  Fastened 1

>  Fastened 2

>  Fastened 3

>  Fastened 4

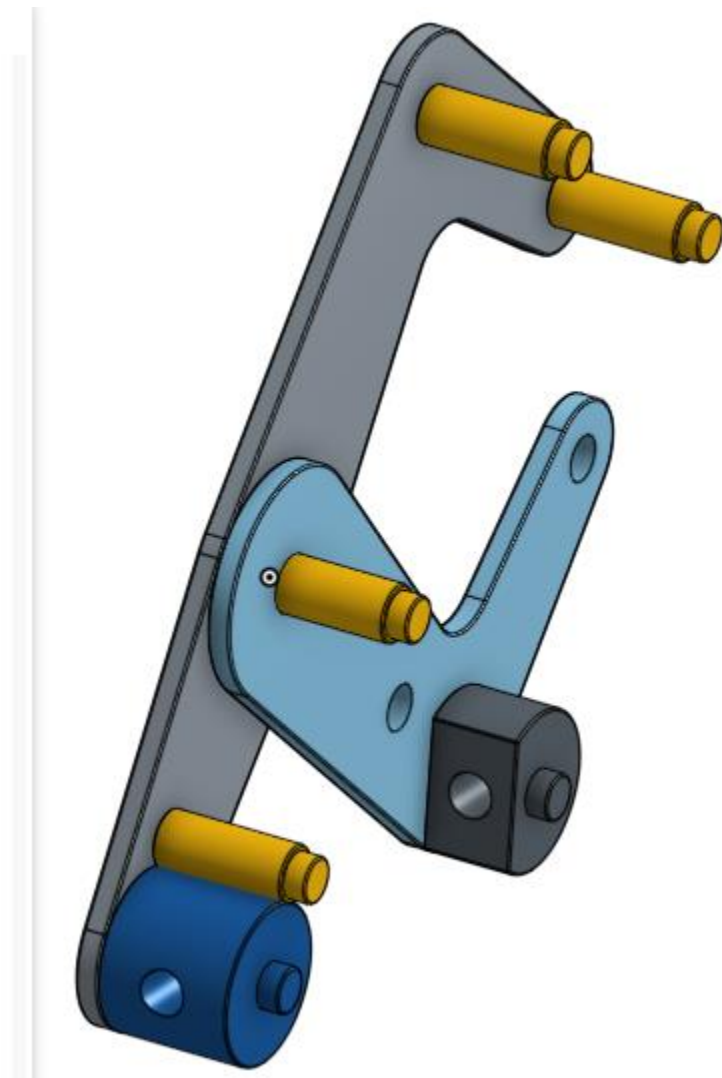

16. Repeat the same process for the Short Pins:

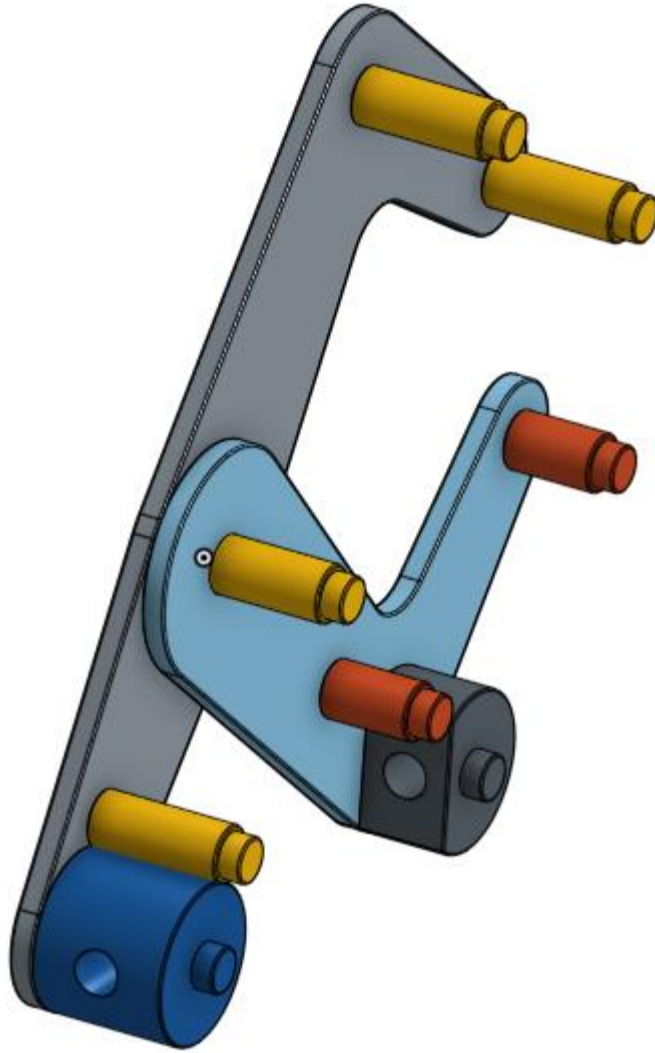

Pro Tip: Be careful when selecting the Mate Connector location on the Pins. In this case, there is a chamfer on the outer diameter. You may be inclined to select the Outer Diameter as the reference for the Mate Connector, but because of the chamfer, the Mate Connector would be in the wrong location (it would be offset by the width of the chamfer, see below). In this case, it is best to reference the Smaller Diameter, or even the edge itself:

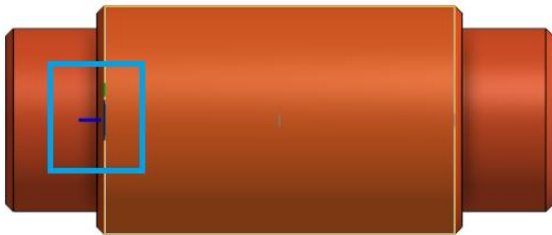
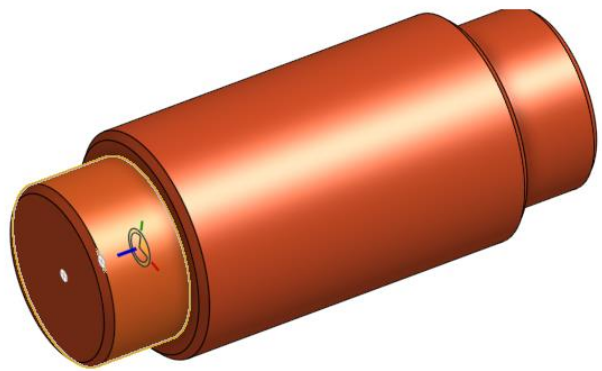
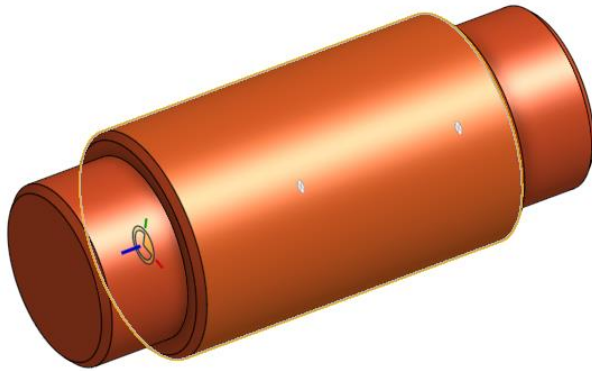

Referencing this surface, includes the chamfer at the end, so it is **incorrect**.

Referencing this surface, does not include a chamfer, so it is **correct**.

17. Next, let's add the grips to the assembly. Starting with the Large Grip, let's use a Revolute Mate, so the grip is free to rotate. In this case, we want to center the grip on the pin that is already assembled. For this, we'll reference the center of the Outer Diameter of the Long Pin and the center of the Inner Diameter of the Large Grip:

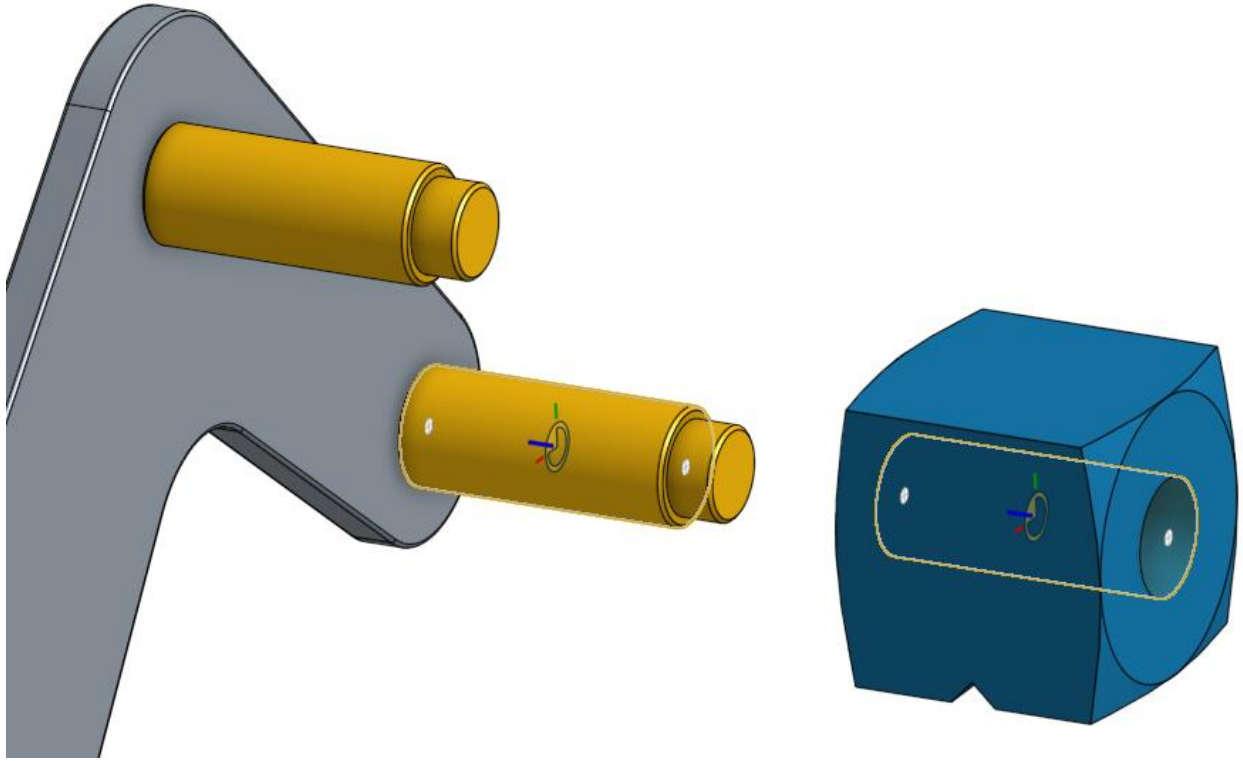

18. Accept the Revolute Mate, and create another one for the Small Grip. We should now have 11 Mate Features:

▼ Mate Features (11)

- > Revolute 1
- > Revolute 2
- > Revolute 3
- > Fastened 1
- > Fastened 2
- > Fastened 3
- > Fastened 4
- > Fastened 5
- > Fastened 6
- > Revolute 4
- > Revolute 5

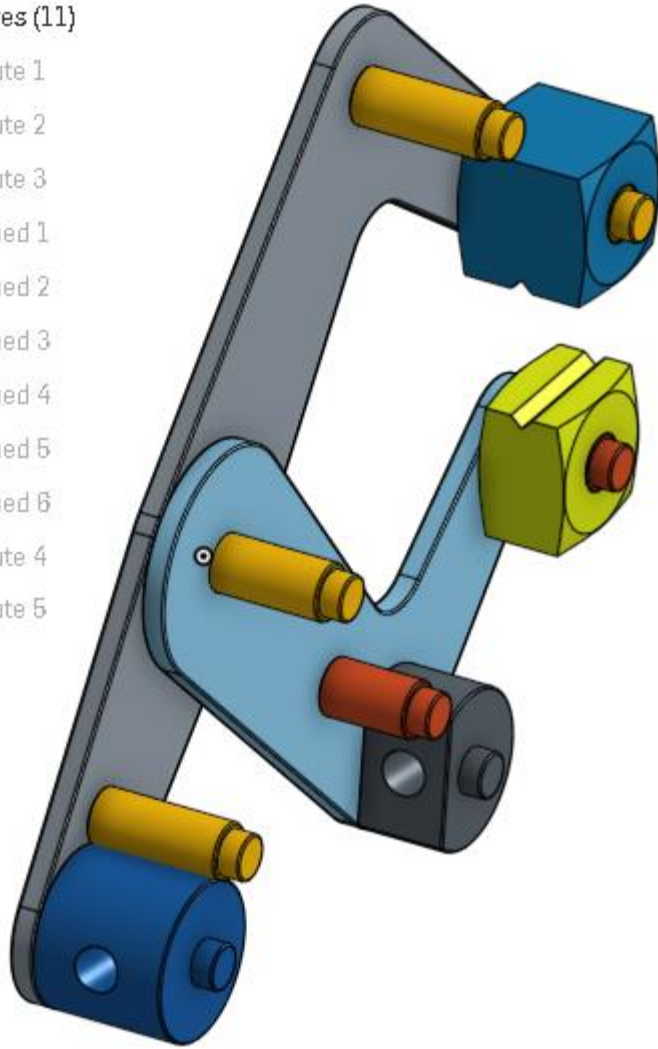

19. Next, let's assemble the Shaft to the End Hinge using a Revolute Mate at the end of the Shaft:

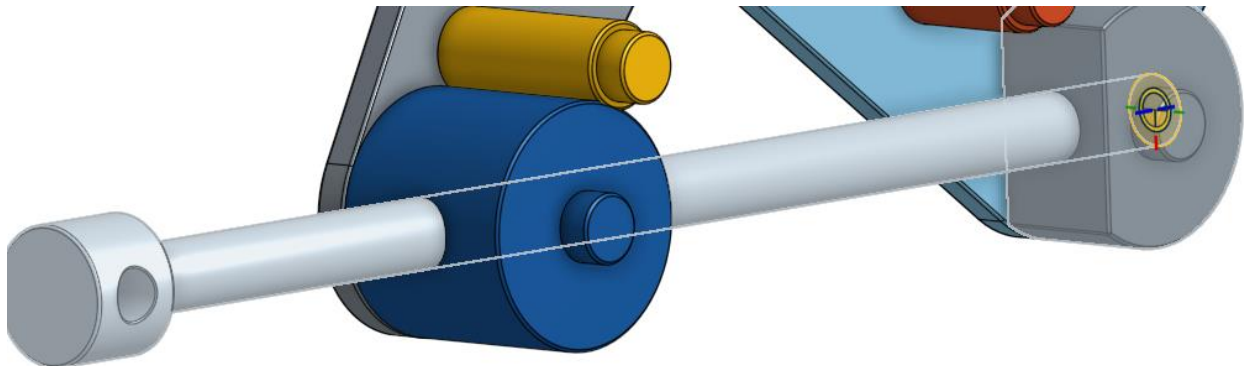

20. Although the Shaft may look assembled, it's not. We can still grab it with the mouse, and drag it down (as shown below), so we'll need to add another Mate.

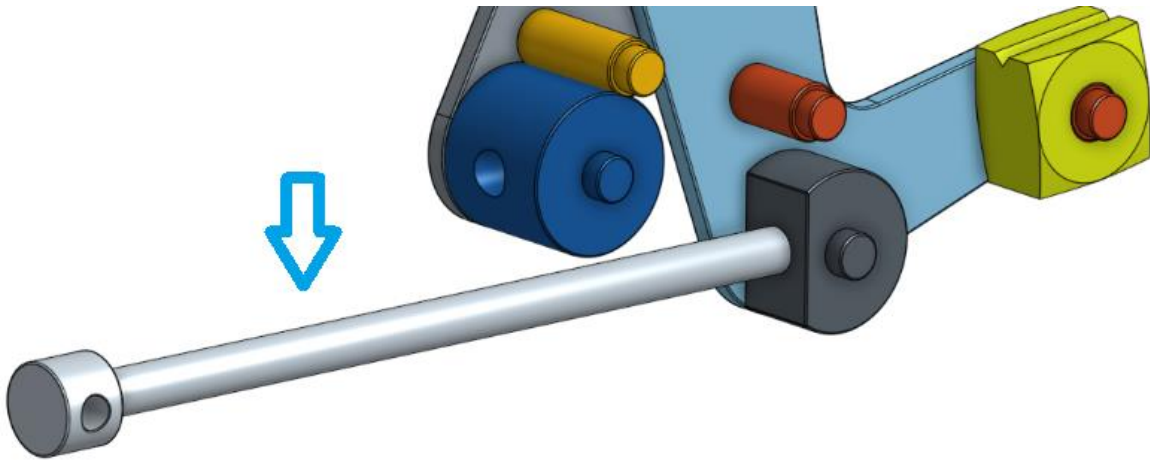

21. Next, we'll use a Cylindrical Mate,  to constrain the Shaft to the Threaded Hinge. Create the Mate Connectors at the center of the Hole for the Hinge, and at the center of the Outer Diameter center of the Shaft, as this is most logical:

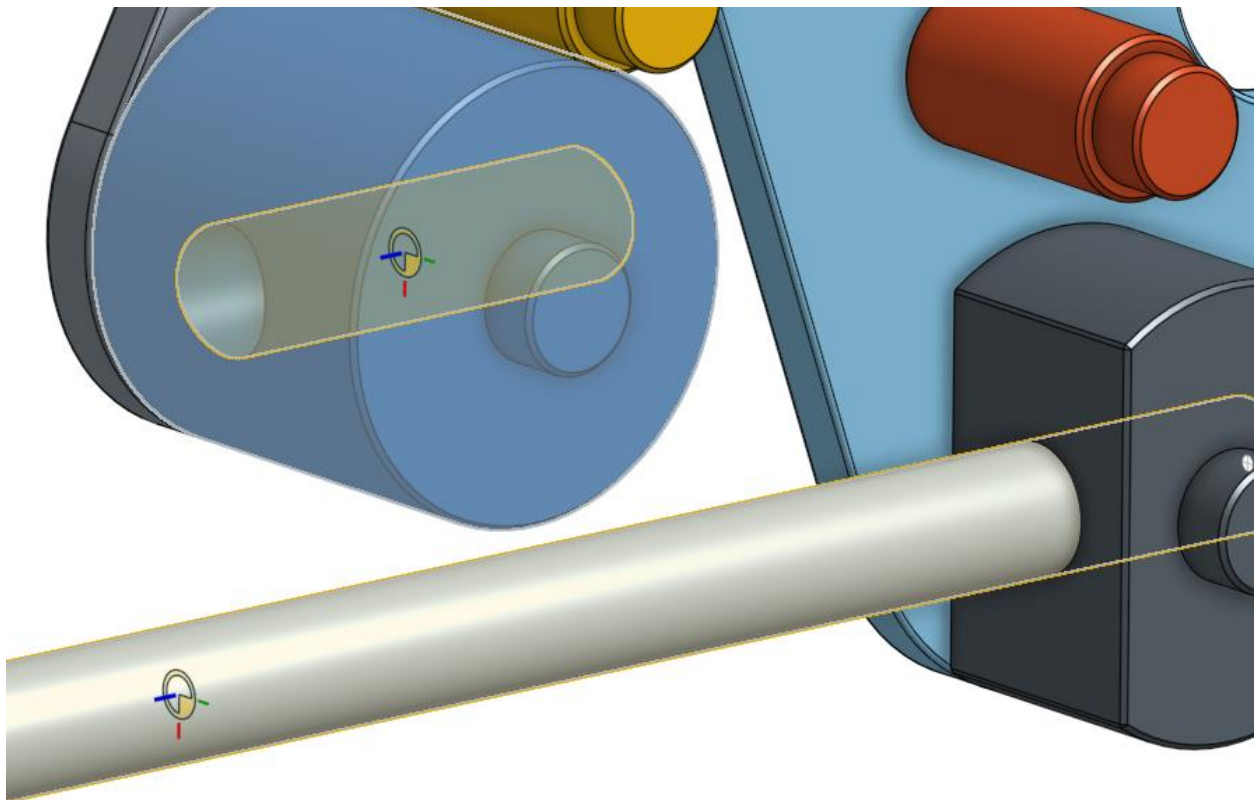

22. The Threaded Hinge will now assemble itself to the shaft. This is just a preview of the Mate (all other mates are temporarily unsolved):

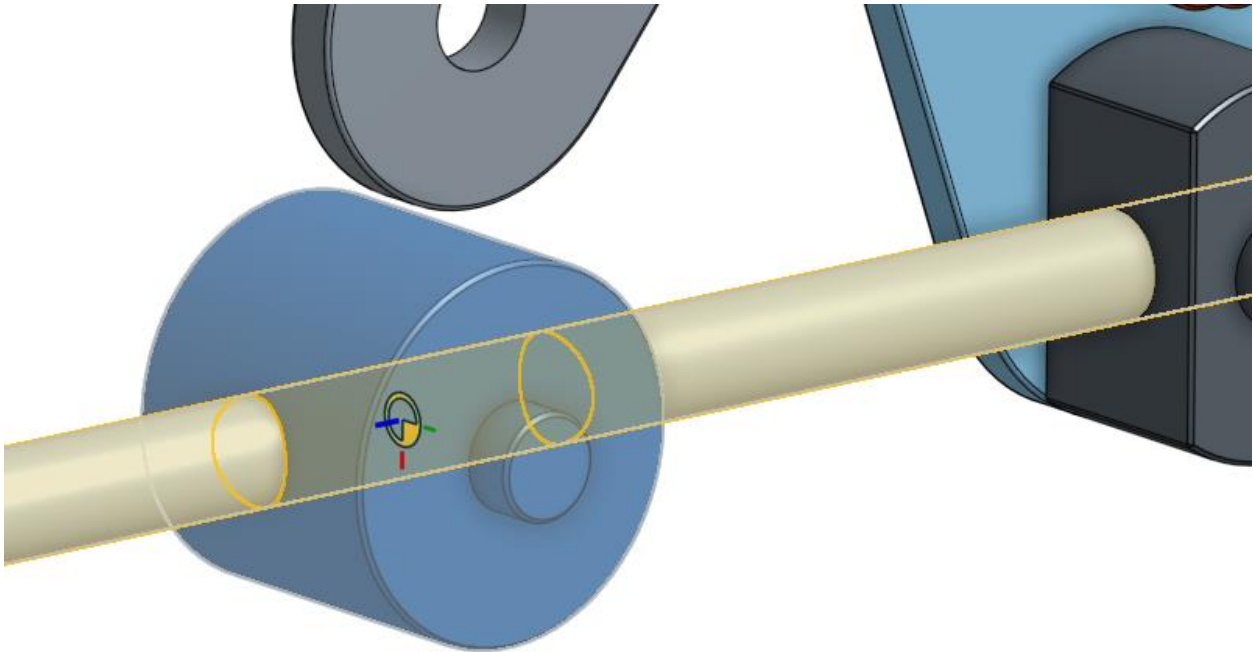

23. Before we accept the Mate, let's see how the Clamp will look with the Threaded Hinge fully assembled. To do this, select the icon in the dialog box. If everything looks okay, then accept the mate:

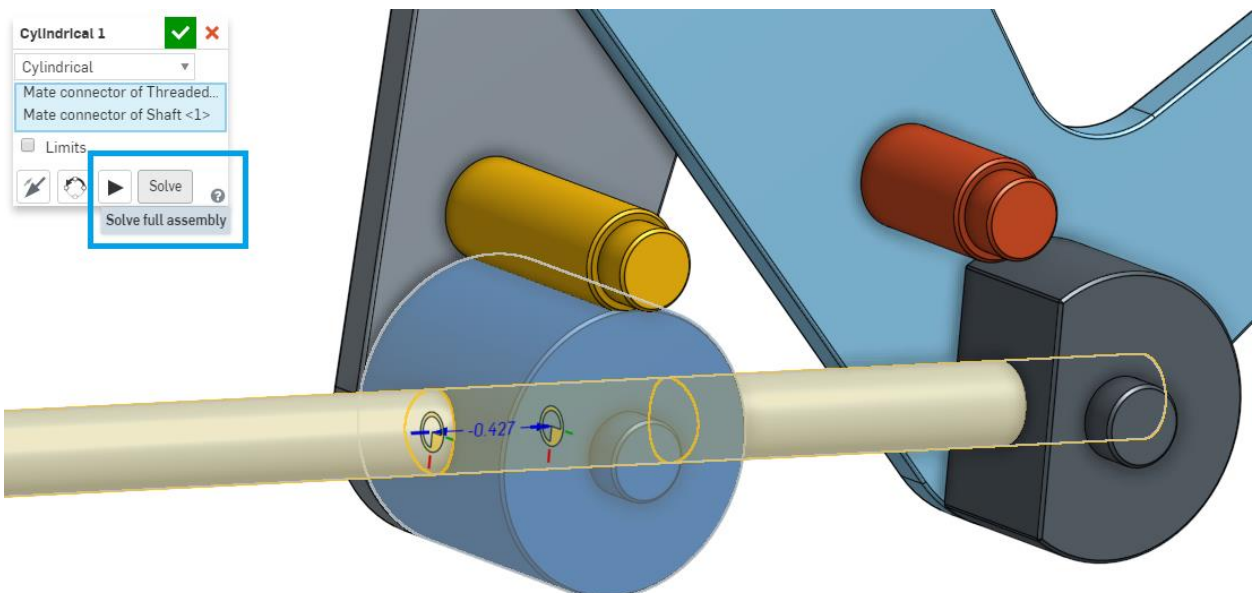

Pro Tip: When you add a mate, Onshape's solver only solves for that single mate. If you want to see what your assembly looks like when all mates are solved together, click the Solve button. This solves all of the mates in the assembly, without accepting the current Mate yet. In complex assemblies, the solve button helps preview the final motion of the part before committing, which can save you a little bit of time, in the case that something is not quite right. Little things like this can add up, and save you significant time in the long run.

24. At this point, if you drag the clamp with the Triad, it should have realistic movement, and both hinges should rotate with the shaft:

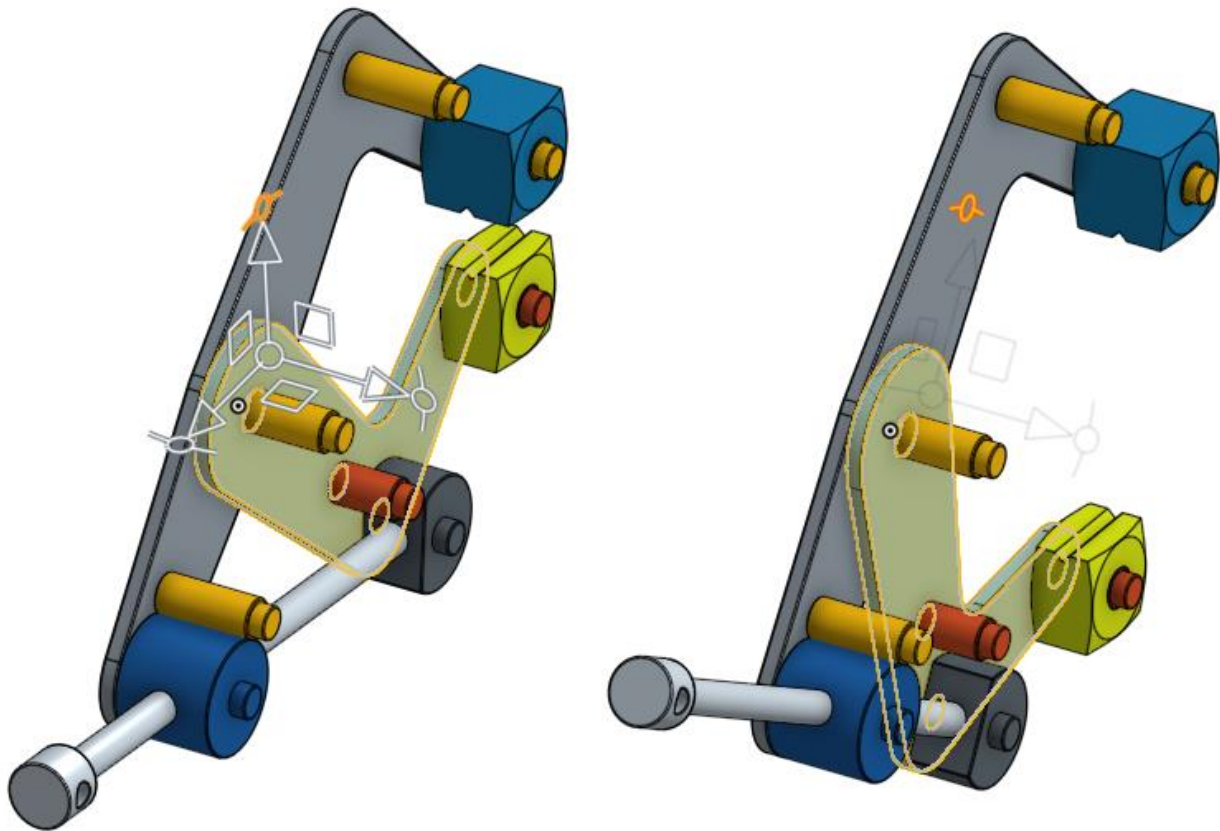

25. Next, let's add the handle to the Shaft, by using a Fastened Mate, and referencing the center of each part's cylindrical surfaces:

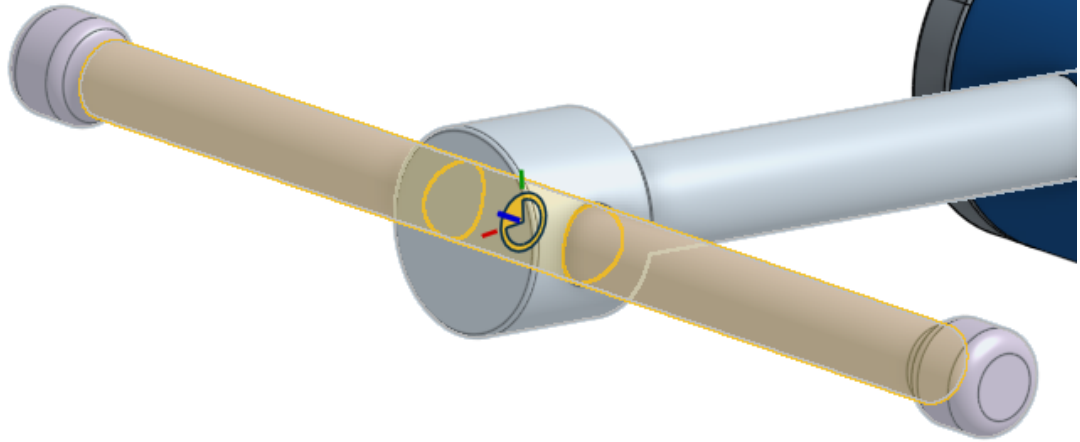

26. Now, let's assemble the second Short Arm, using Fasten Mates. Here, we'll use the pins as reference:

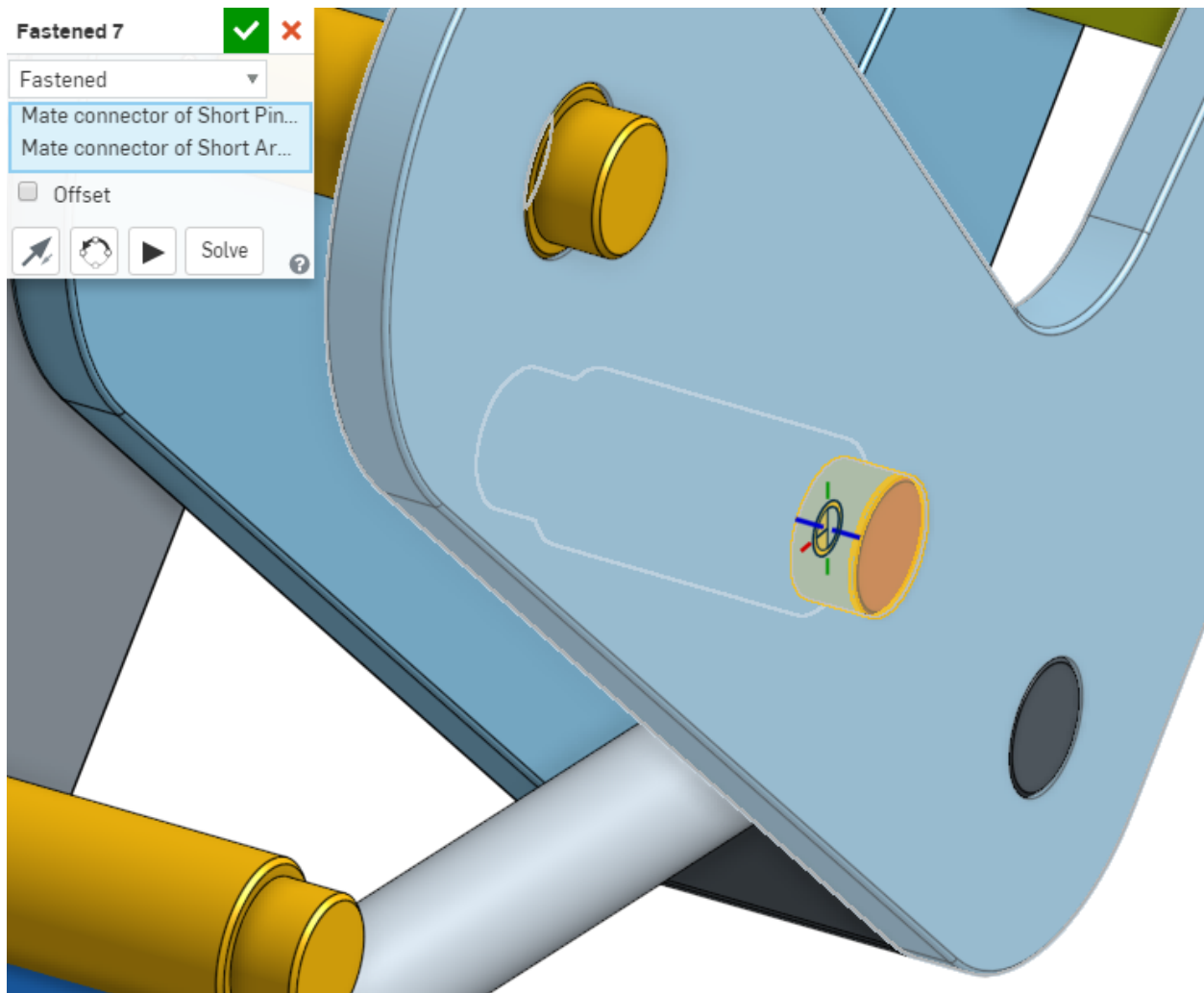

Pro Tip: At this point, there are many references that we could use to place our Mate Connectors and Mates. Assembling our clamp in CAD is a simulation of doing it in real life, and so we want to use the most logical references for our Mates. In this case, the center pin is the best choice because in real life this pin is pressed into both short Arms, and there is no relative movement between them.

27. Next, we'll assemble the second Large Arm. Using the same logic as above, we'll use the middle Long Pin as our Mate reference, because it is pressed into both Long Arms, and there is no relative motion between the parts in real life:

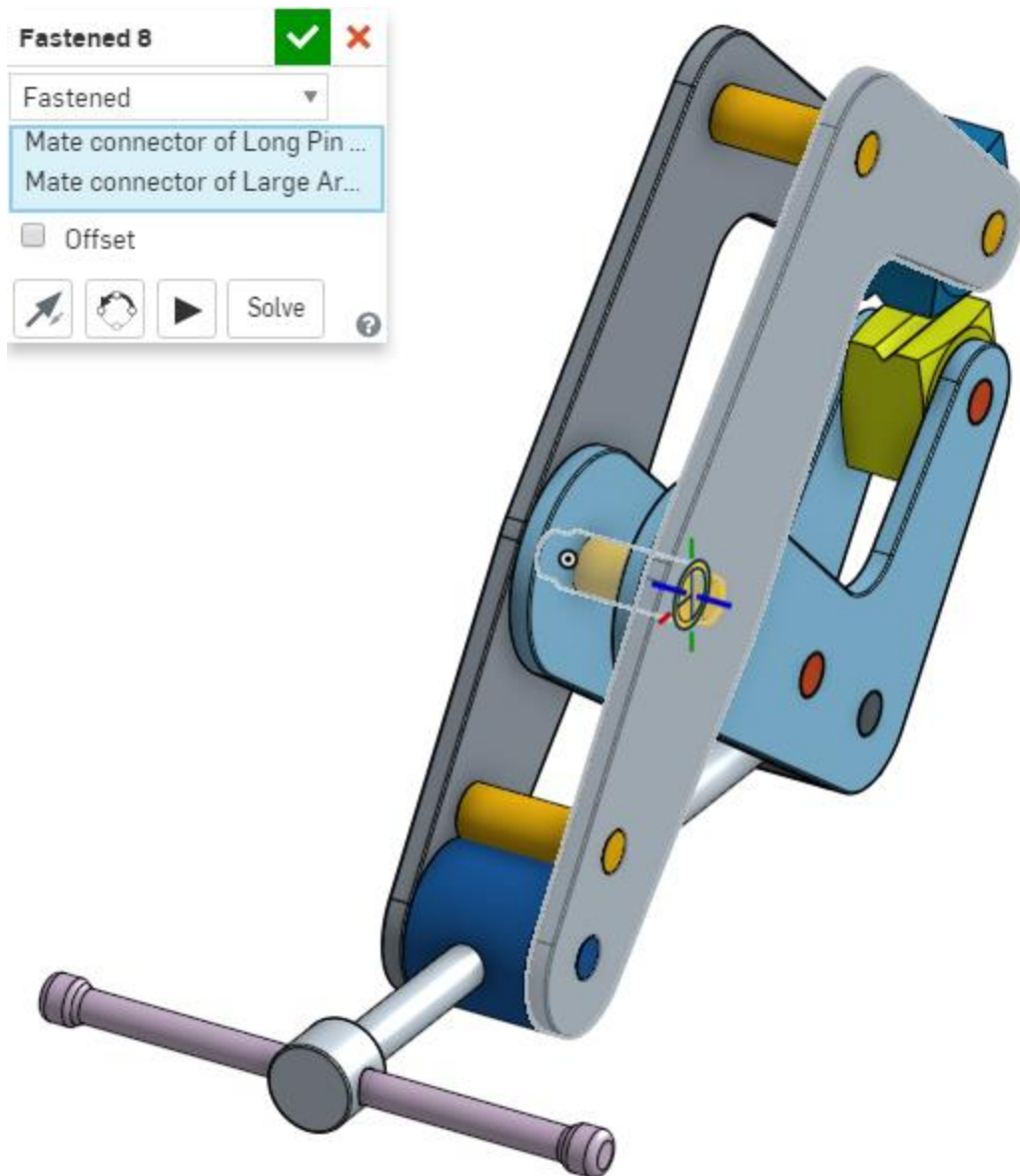

Relations

A relation is a way in Onshape to constrain degrees of freedom between two Mates. Where a Mate controls how many degrees of freedom a pair of parts has between them, a Relation can control how those degrees of freedom move with respect to each other. There are 4 types of Relations in Onshape: Gear, Rack and Pinion, Screw, and Linear. These relations rely on pre-existing Mates to define the type of motion that will occur between two parts. For more information, review the Onshape Help <https://cad.onshape.com/help/#relations.htm>.

28. Next, let's create a Screw Relation between the Shaft and the Threaded Hinge. This will create the realistic movement as if the shaft were threaded through the Hinge. To do this, select the Screw Relation Icon . Select the Cylindrical Mate that was already created, and make the distance per revolution = $\frac{1}{4}$ ", and reverse the direction:

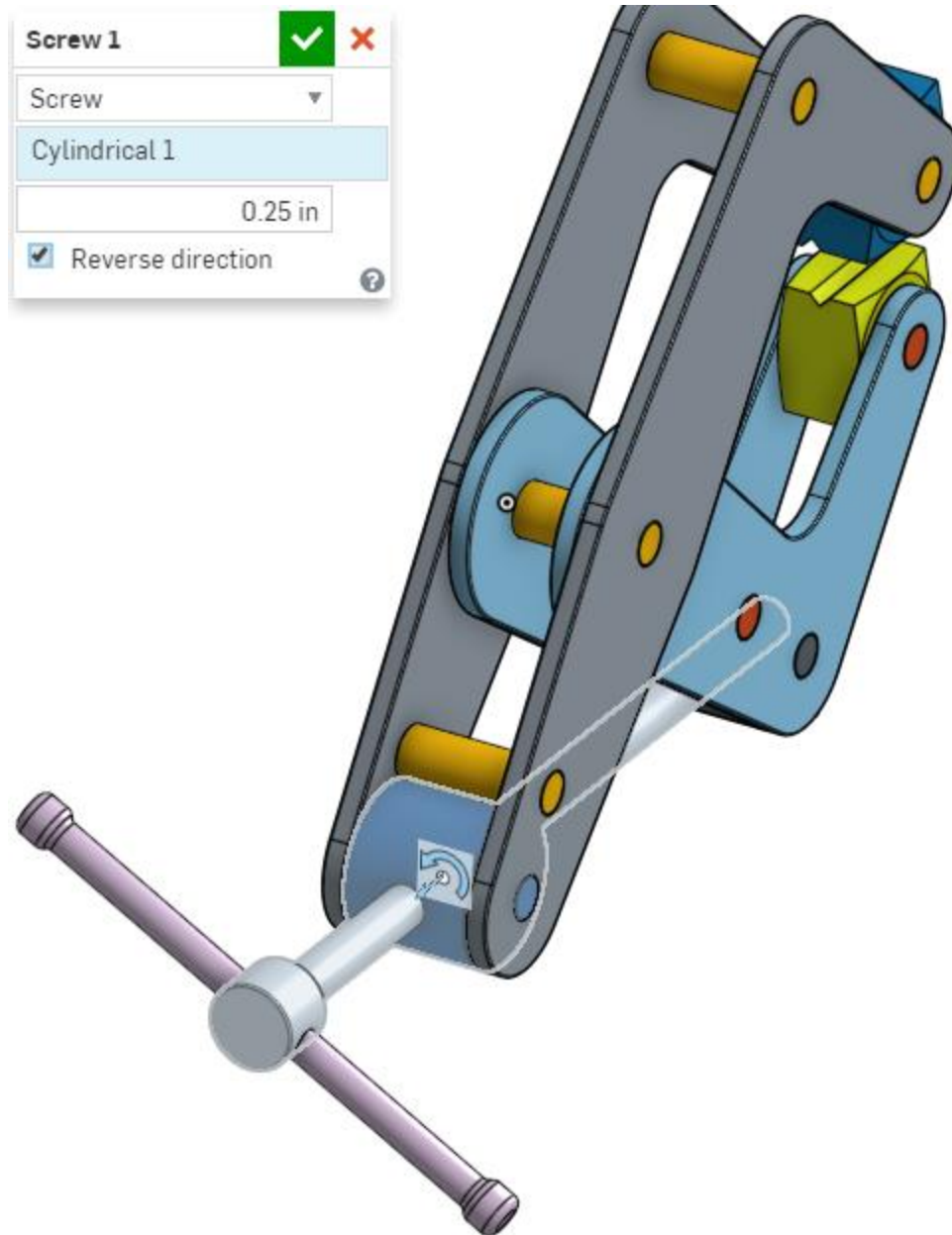

29. Now, the Clamp should show realistic movement, either by rotating the handle, or dragging the Short Arm! Congratulations, you have just completed your first Onshape assembly!

Pro Tip: After you complete a big task, like building this assembly, take a step back and reflect on the work that's been completed. Have the parts been designed properly? Does the motion accurately reflect the real life assembly? Is symmetry maintained where it needs to be? Are there any interferences? Have the proper relations been created? Could you manufacture the part as designed? Has the original design intent been captured? The answer should be yes to all of these questions. In the case of our Clamp, we have effectively used top-down design by

creating a Multi-Part Design in a Part Studio, then correctly simulated accurate motion in an Assembly. Good Job!

In-Class Exercise #2:

Now, we're going to gain more practice assembling parts with this vise:

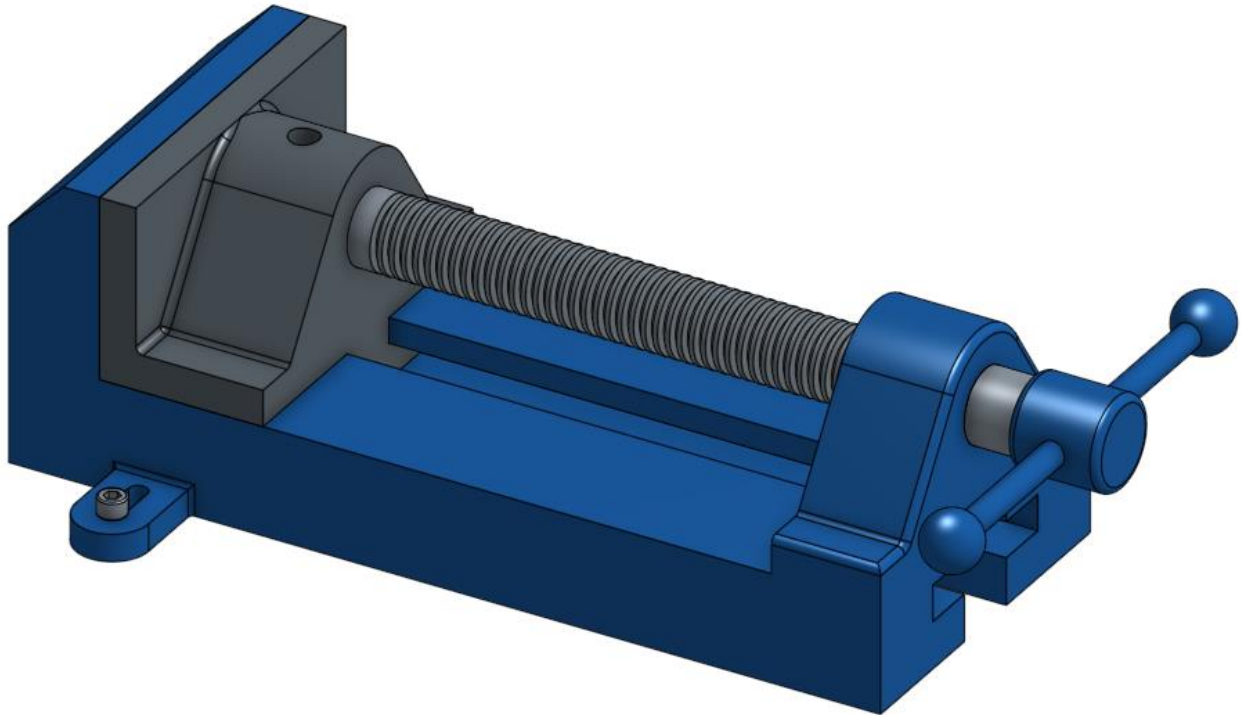

1. Let's start by creating a new document, and navigating to the assembly tab. Insert a new part, and navigate to the "Browse Documents" tab:

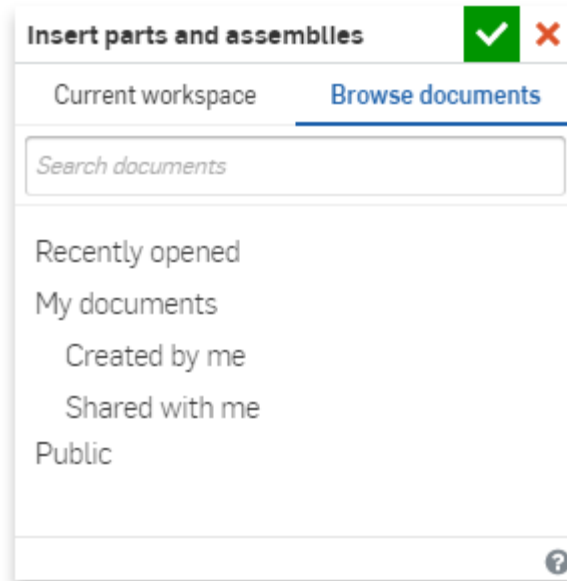

2. Click on Public, and you'll see the "College - Assembled Vise" model that we will be assembling:

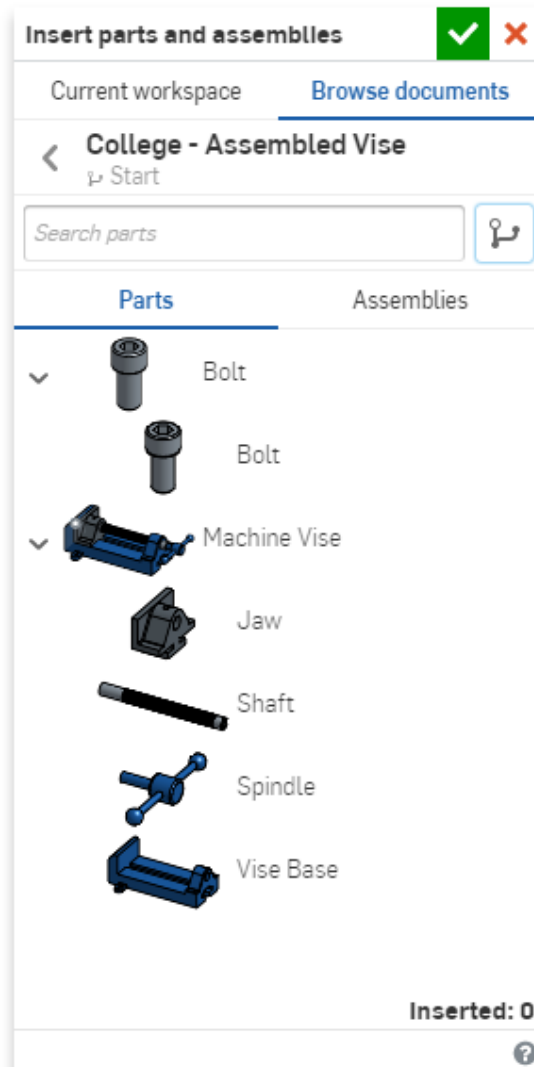

3. By selecting the entire Machine Vise Part Studio, we'll be able to bring all of the parts in at once. Select the Green Checkmark to place everything in its original position. Right-click on the Vise Base, and select "Fix". Now, use the triad to "explode" everything out. Note that the Vise Base already has two Mate Connectors (we will discuss why and how this got here later in the course):

- Instances (5)
- Origin
 - 📄 Jaw <1>
 - 📄 Shaft <1>
 - 📄 Spindle <1>
 - ✓ 📄 Vise Base ...
 - 🔄 Mate connector 1
 - 🔄 Mate connector 2
 - > 📄 Bolt <1>
 - ✓ Mate Features (0)

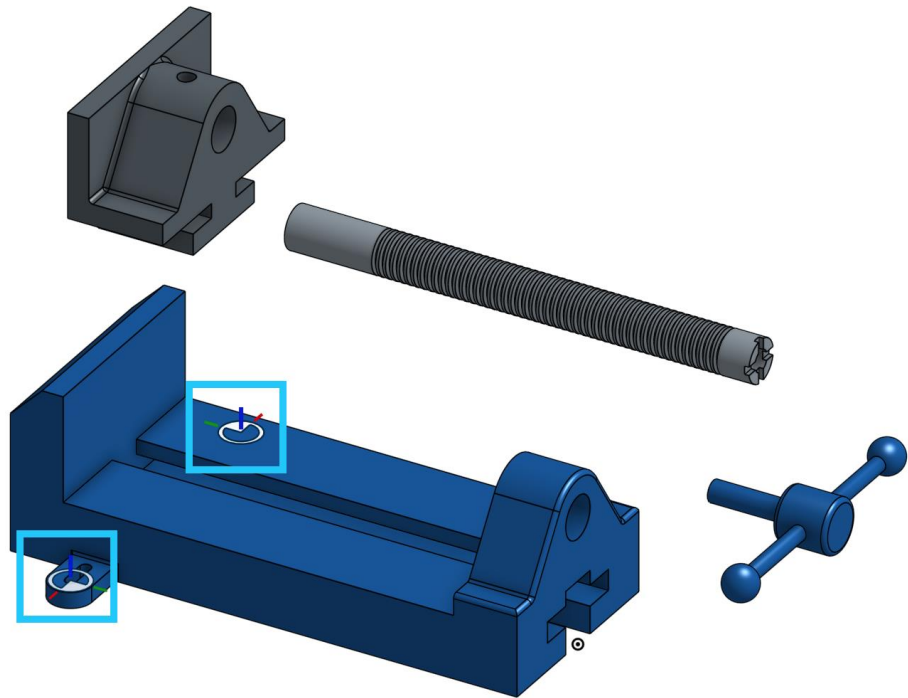

Pro Tip: This is a common and helpful starting point for any assembly. (1) With the Vise Base in its original position and fixed in place, it gives us a solid foundation to start assembling other parts to. (2) By inserting the entire Part Studio, we know we haven't accidentally missed any parts. (3) With the parts exploded, all of the faces are exposed for us to use as a reference for our Mate Connectors. Approaching assemblies in a systematic way like this, can make designing in CAD fast and fun.

4. First, let's use a Cylindrical Mate to constrain the Shaft:

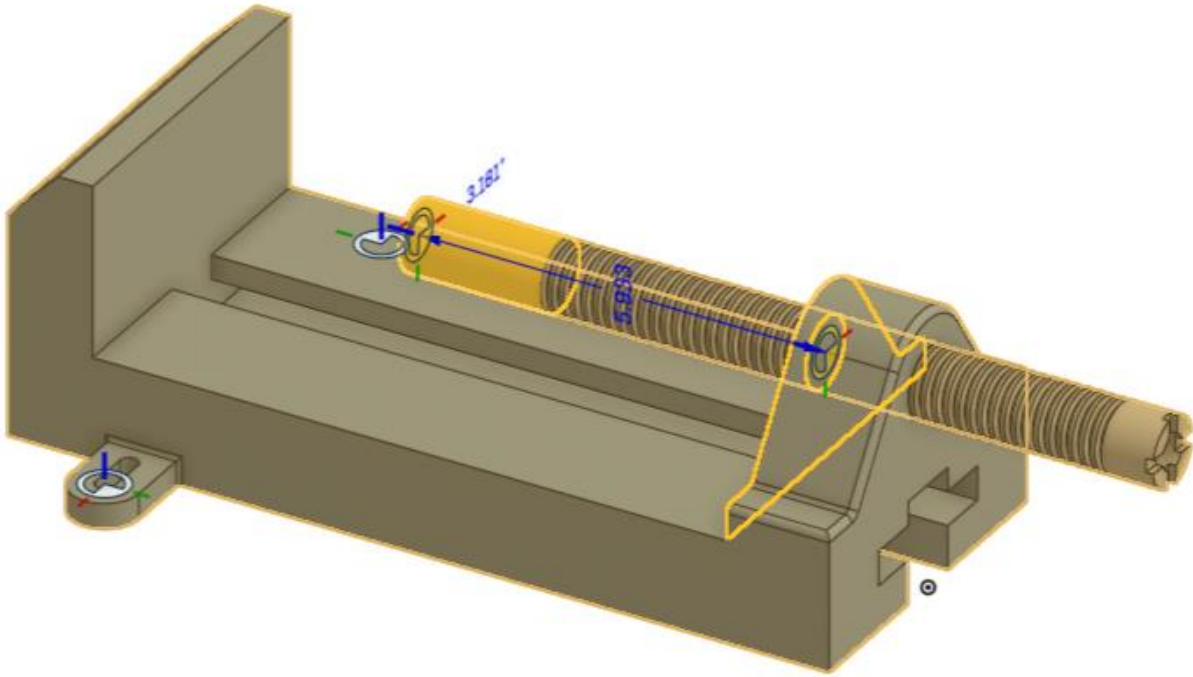

Pro Tip: Since a Cylindrical Mate allows rotation around and translation along the blue axis, the location of the Mate Connectors can be anywhere along the shaft. For the Vise Base, referencing the hole is the smartest, because that is what constrains the shaft in real life.

- Next, let's assemble the Spindle using a Fasten Mate:

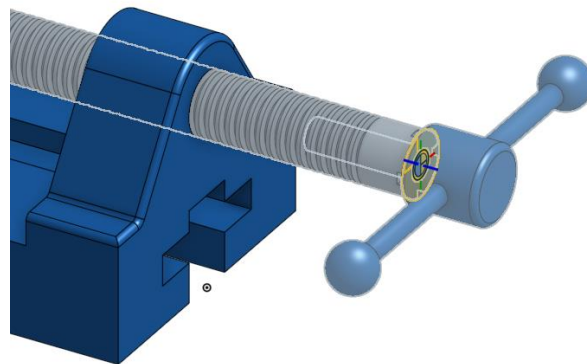

- Next, we'll assemble the Jaw. The Jaw will need two Mates, because we need to control its motion in two ways: it needs to slide back and forth and stay oriented properly, and it needs to move with the shaft. First, we'll address sliding motion. For this, we'll use a Slider Mate, and reference the bottom edge of the Jaw and the top edge of the Vise Base for the Mate connectors:

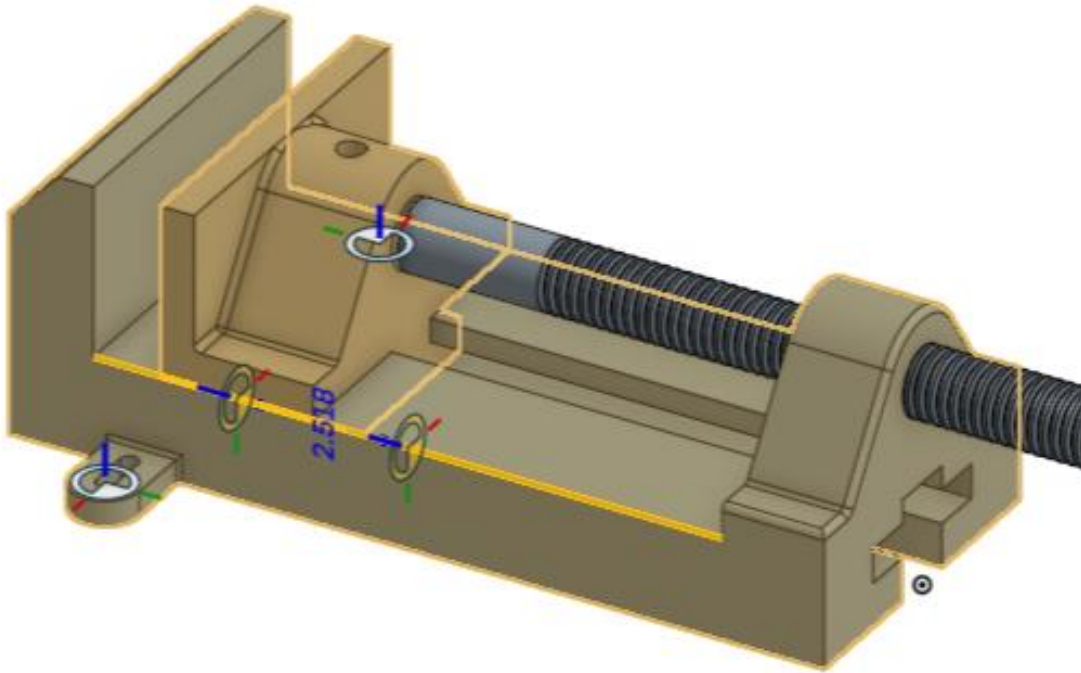

Pro Tip: A Slider Mate only has one degree of freedom, and that is translation along the Z (blue axis). In this case, there are several geometries that can be referenced, but we want to make sure that whichever ones we select, that the blue axes of the Mate Connectors are aligned, like in the picture above. Soon small details like this will become second nature!

7. Next, let's assemble the Jaw to the Shaft. For this, we'll use the Revolute Mate, because we want to allow the shaft to rotate, and we'll reference the bottom of the hole in the Jaw, and the end face of the shaft as shown here:

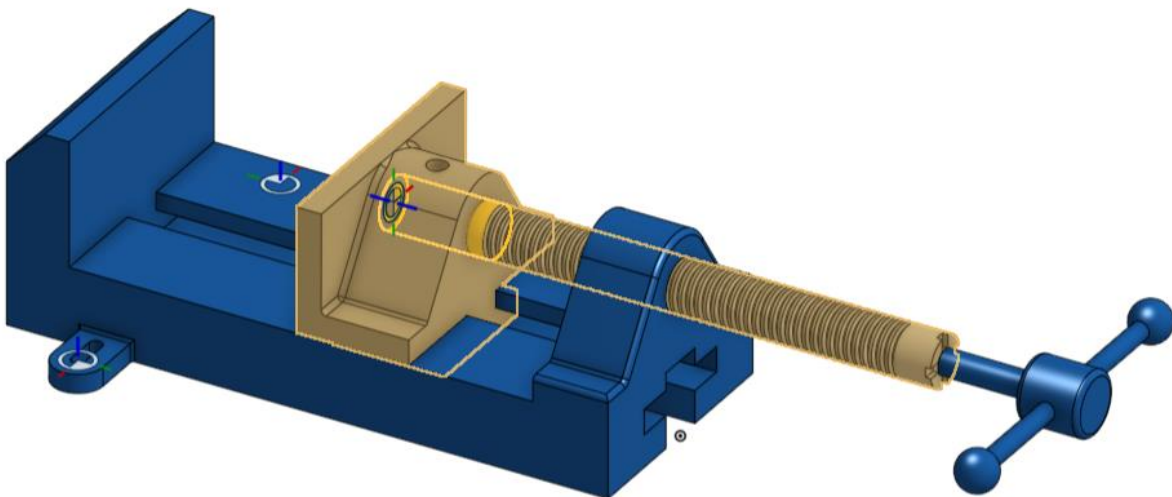

8. Now, we should be able to slide the Jaw back and forth, and rotate the Spindle. Using the triad, check the motion:

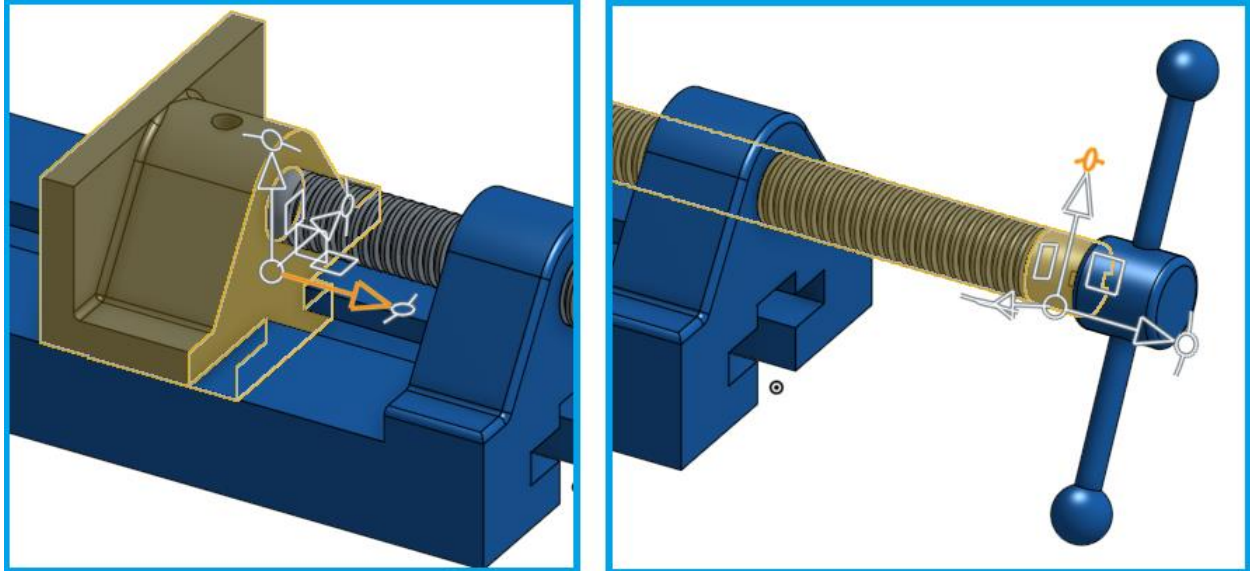

9. Just like the previous Clamp model, let's add the realistic motion of the threads. Referencing the Cylindrical Mate, we'll use 0.5" per revolution. :

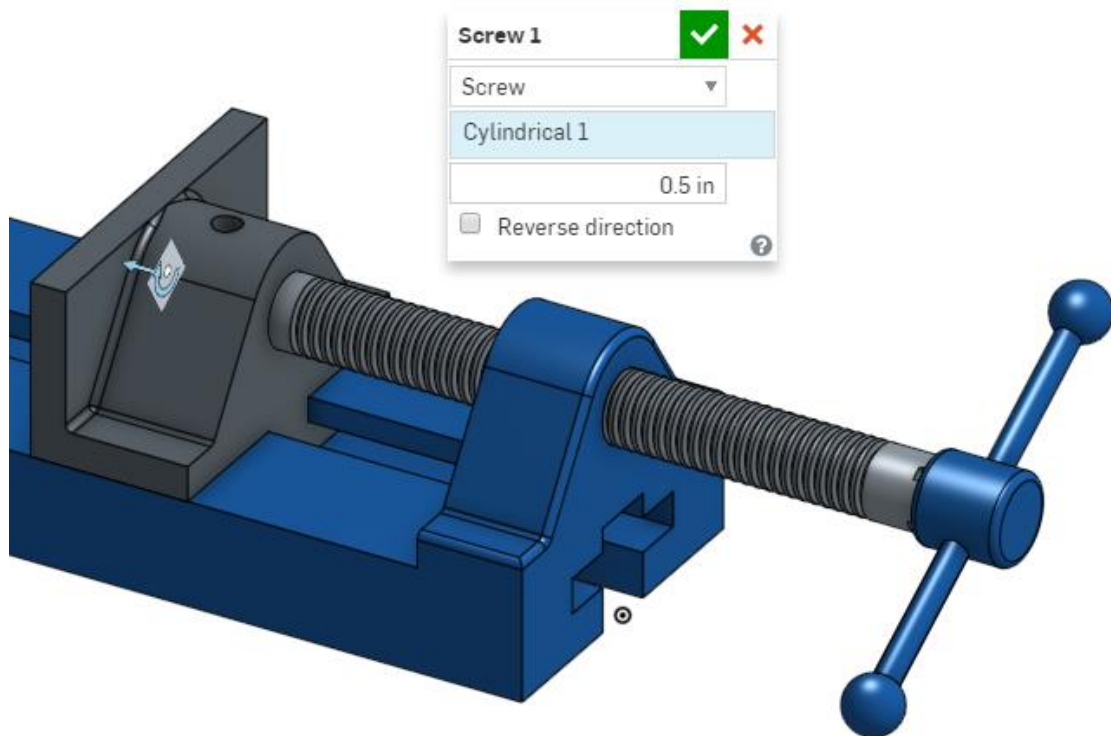

Limits

The following exercise discusses the Pin Slot, and an application of adding a “Limit” to a Mate. More information can be found in the help here: https://cad.onshape.com/help/#mate-pin_slot.htm

10. Finally, we will add the Bolts to the assembly. Browse for the “College - Assembled Vise” model again, and select the Bolt. Notice how the Bolt already has a Mate Connector:



11. We're going to be creating the Pin Slot Mate  , which mates two parts allowing rotational movement about the Z axis and translational movement along the X axis. We want to bolt down our vise, but the Bolt can be at any point along the axis of the slot, so we'll have to use **limits** to restrict the translational movement along the X axis, as shown by the bright blue arrow in the picture below. But we don't care if the Bolt rotates about its own Z axis, so we won't need to limit the rotation:

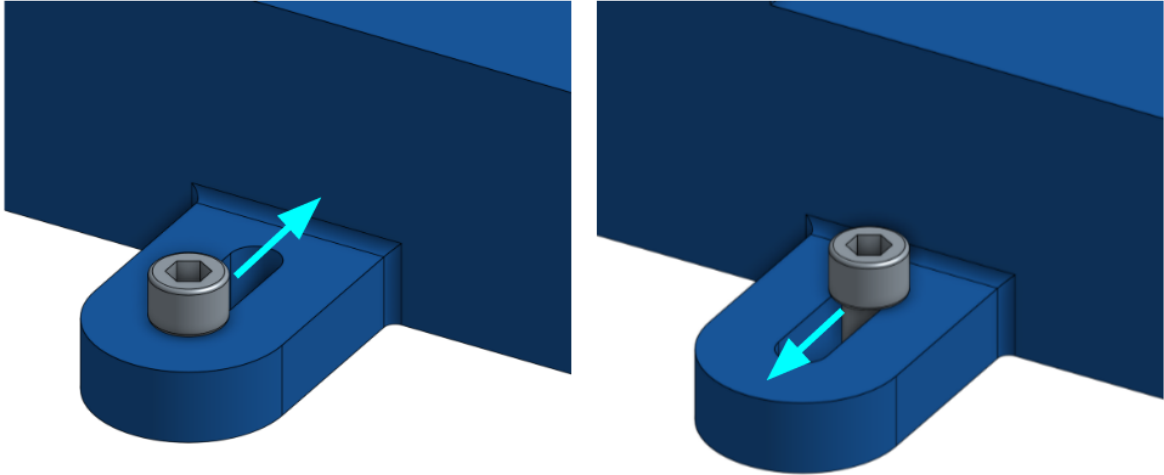

12. Let's create the Pin Slot Mate using the CONNECTION_POINT Mate Connector on the Bolt and one of the Mate Connectors already included in the Vise Base. Don't accept the Mate just yet:

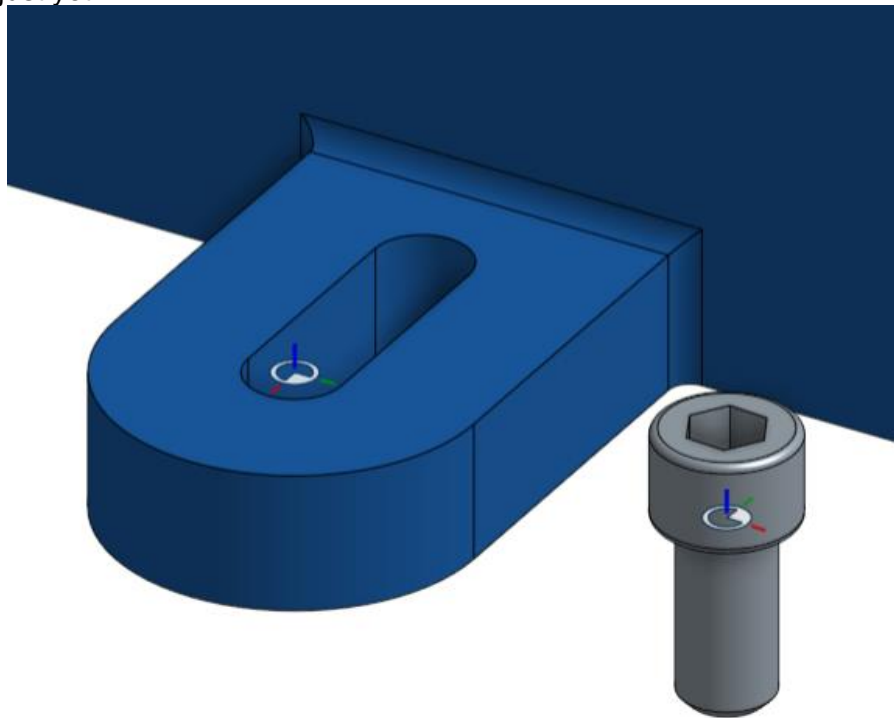

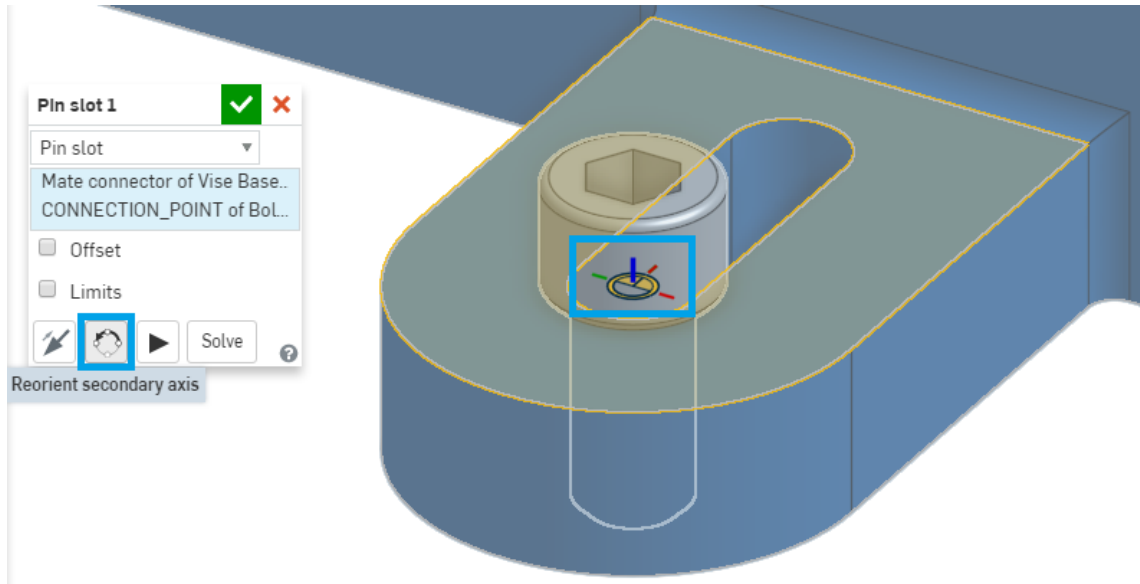

13. Click on the Play button to animate the mate degree of freedom . If your Bolt doesn't move along the slot in the right direction, rotate the Mate using the "Reorient secondary axis" in the dialog box:

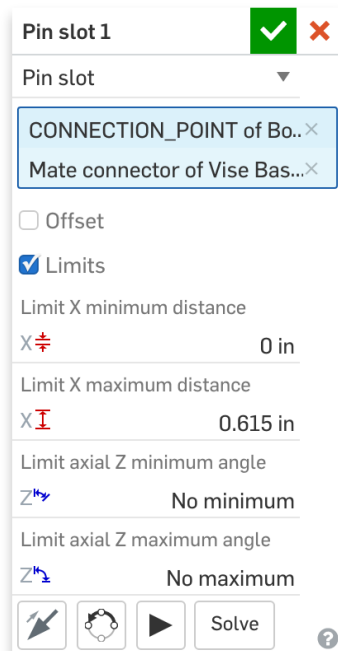

14. Clicking this button once will rotate the Mate Connector 90 degrees clockwise, so click on it until the Bolt moves in the intended direction along the slot during the animation.

15. You probably also noticed that the Bolt slides past the slot. We'll fix this by using limits. The length of the slot is 0.615" (we measured this for you), which is going to be how far the pin slot can travel from its original point. Let's add the limit to the Pin Slot Mate. To do this, unhide the Bolt. Double-click on the Pin Slot Mate you made earlier and then click on the Limits toggle box. Constrain the slot to move between 0 - 0.615":



16. Press the animate button . The Bolt should now only move along the slot and back. Now accept the Pin Slot Mate. You've successfully added limits to the Pin Slot Mate!

17. Repeat this process for the other Bolt. Now, the Vise should show realistic movement, either by rotating the Spindle, or dragging the Jaw, and the Bolt should stay within the limits of the slot. Congratulations!

After this class, you should now start to feel comfortable creating Parts, Multi-Part Designs, and Assemblies. As you progress as a designer, you will develop a keen eye on how things around you are designed and assembled. When assemblies are built in Onshape, it is really just a simulation of how things are assembled in real life. Onshape's Mate Connectors are very powerful in that they can accurately describe any kind of motion all by themselves. When building assemblies always be thinking ahead to the type of motion you want (Fastened, Sliding, Pin Slot, etc.) and which geometry to reference the Mate Connector to. Approach the design of assemblies with discipline and attention to detail, and you will be able to design complex assemblies with speed and accuracy.

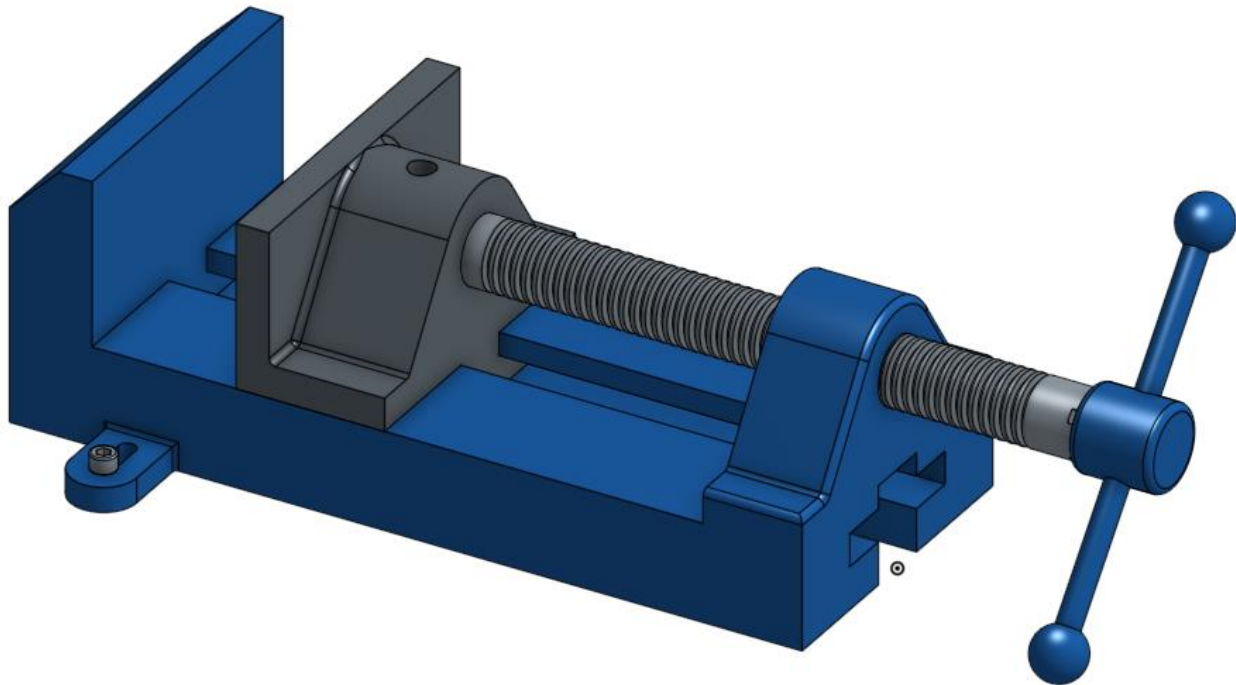

Summary

Let's take a second to reflect what we learned in this lesson.

1. We learned about degrees of freedom and how mates limit the part's degree of freedom.
2. We learned about Mate Connectors and how to use them to mate two parts together.
3. We learned how to move parts within an assembly using the triad manipulator.
4. We learned that you can animate the Mate in Onshape.
5. We were introduced to the 4 types of Relations in Onshape: Gear, Rack and Pinion, Screw, and Linear.

6. We learned that you can add limits to Mates.

Next week, we will be switching gears and will introduce Engineering Drawings, how to make them in Onshape, and why they are useful in the manufacturing process.